



Seeing the Sky

Visualization & Astronomers

Alyssa A. Goodman

Harvard Smithsonian Center for Astrophysics & Radcliffe Institute for Advanced Study

@aagie



HARVARD
UNIVERSITY

Microsoft
Research



SEAMLESS
ASTRONOMY
Linking scientific data, publications, and communities



Authorea

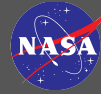

AMERICAN ASTRONOMICAL SOCIETY
Enhancing and sharing humanity's scientific understanding of the universe since 1899.



$$F = \frac{Gm_1m_2}{R^2}$$

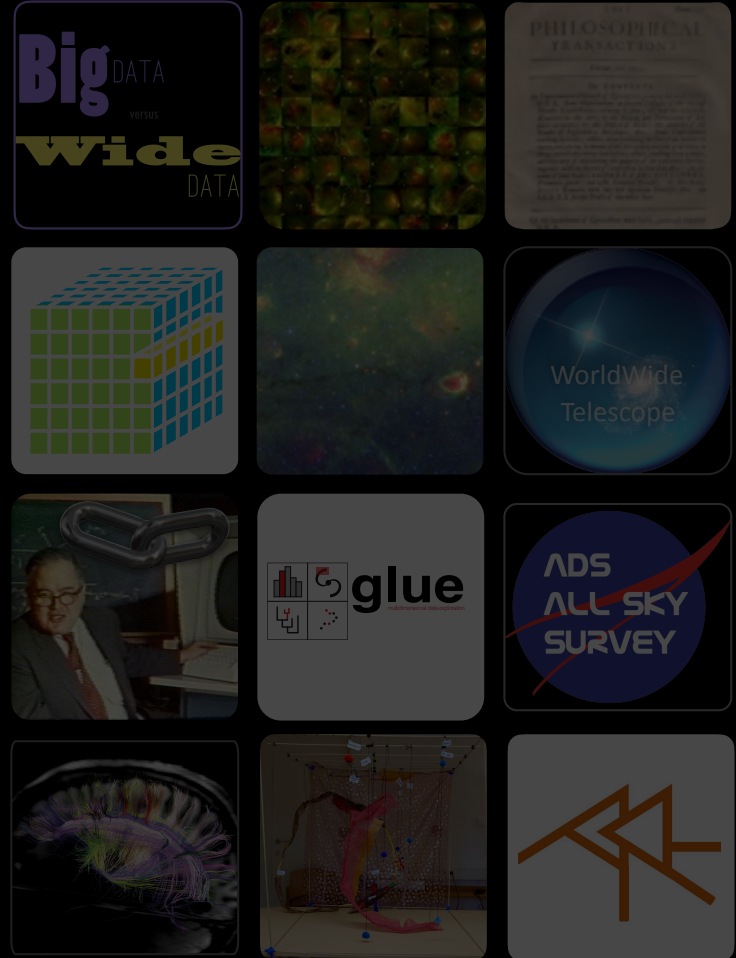
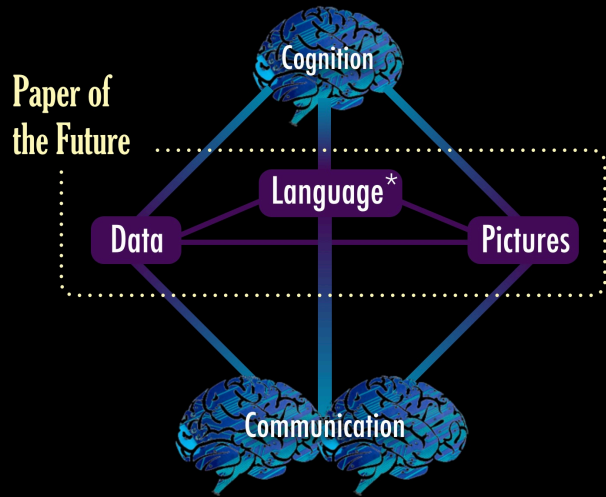

“Paper of
the Future”

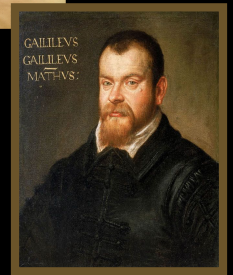
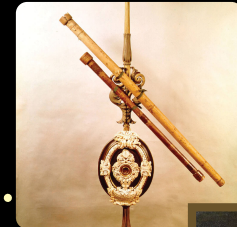
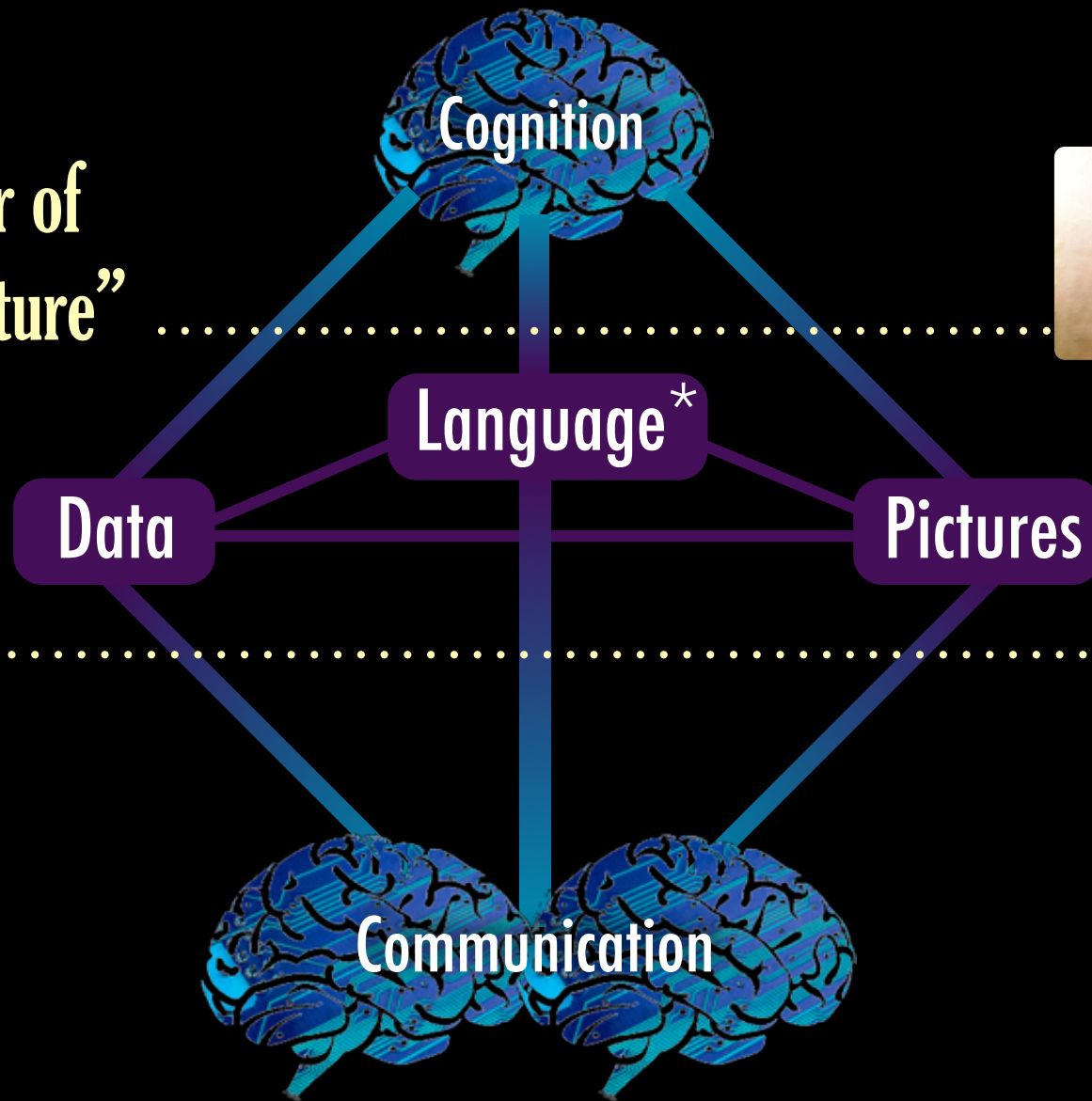

*“Language” includes words & math



GALILEO'S "NEW ORDER"

Created by Alyssa Goodman, Curtis Wong and Pat Udomprasert,
with advice from Owen Gingerich and David Malin



Galileo's New Order, A WorldWide Telescope Tour by Goodman, Wong & Udomprasert 2010
WWT Software Wong (inventor, MS Research), Fay (architect, MS Research), et al., now open source, hosted by AAS, Phil Rosenfield, Director
[see \[www.wwtambassadors.org\]\(http://www.wwtambassadors.org\) for more on WWT Outreach](http://www.wwtambassadors.org)



January 11, 1610

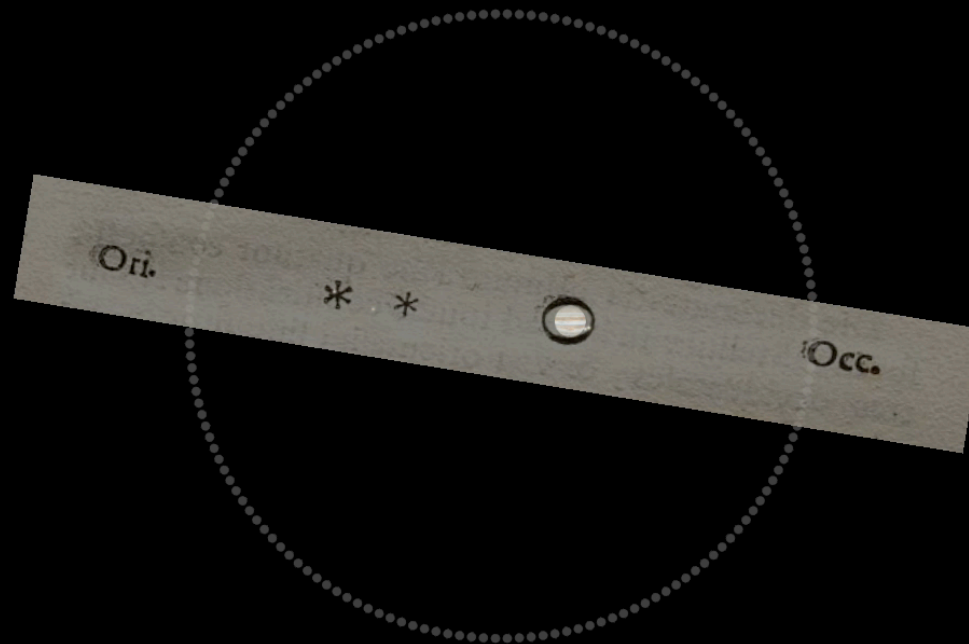

“Paper of
the Future”

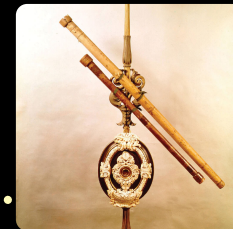
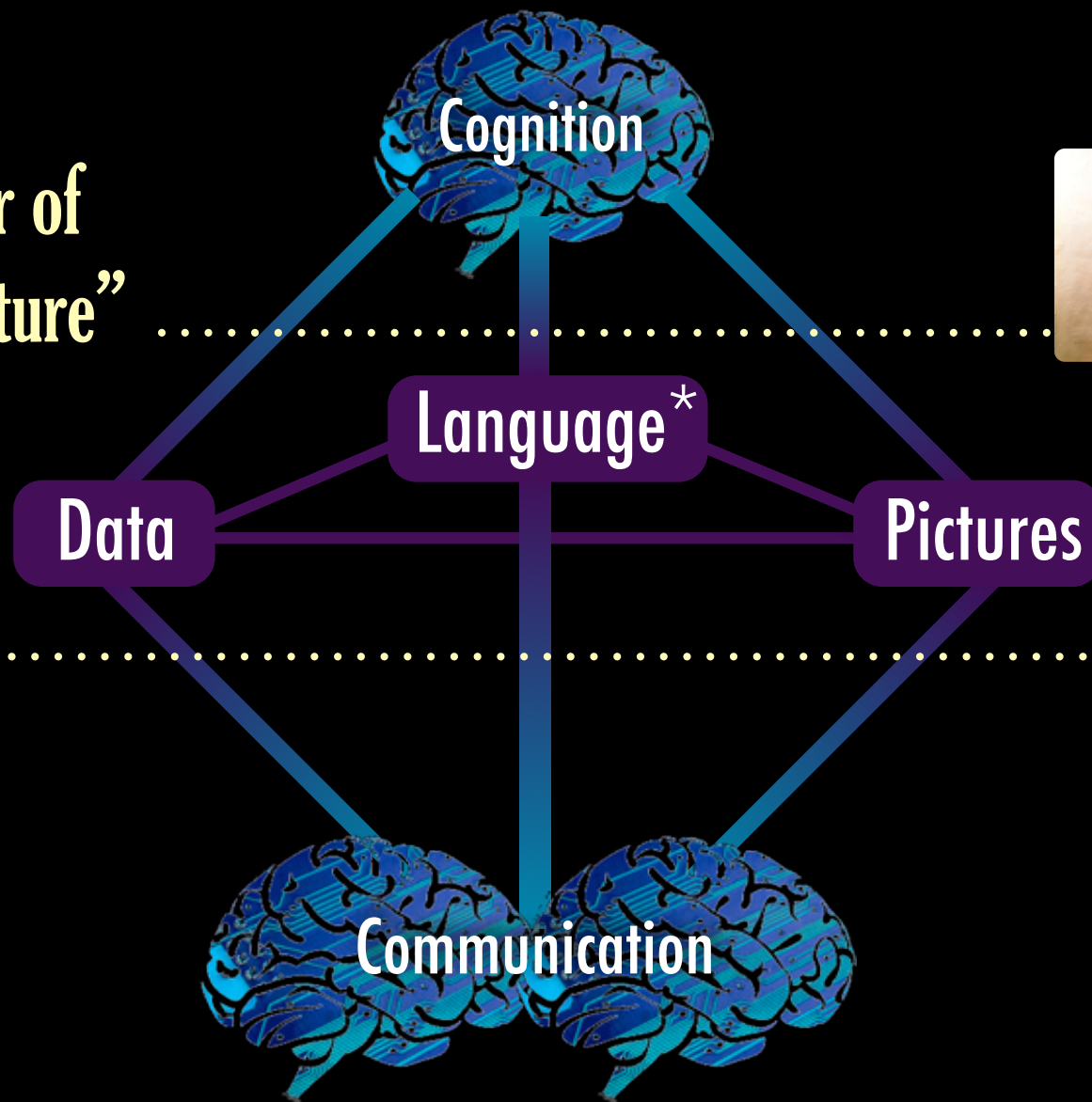

*"Language" includes words & math

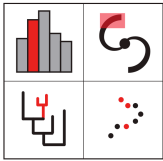

glue

multidimensional data exploration

enabled by d3.js (javascript) outputs



d3po

d3po is a project designed to allow an astronomer (or anyone), with no special data visualization skills, to make an interactive, publication-quality figure that has staged builds and linked brushing through scatter plots. Our current version can be previewed at d3po.org, and represents a figure from upcoming work by graduate student Elisabeth Newton. The figure describes how metallicity affects color in cool stars, and represents a nice use case for d3po. Try clicking and dragging in the scatter plots to understand the power of linked brushing in published figures.

Right now we are in search of alpha testers, who have figures that could be made interactive and who are willing to get their hands a little dirty (No javascript skills needed). In future versions, we plan to link to glue to allow the creation of d3po figures interactively. We are also exploring [implementation](#) of d3po within presentations and within [authorea](#). Full 1.0 version expected in January 2014.

Installing your own d3po server

```
git clone git@github.com:adn/d3po.git
cd d3po
virtualenv --no-site-packages venv
source venv/bin/activate
pip install -r pip-requirements.txt
python run.py
```

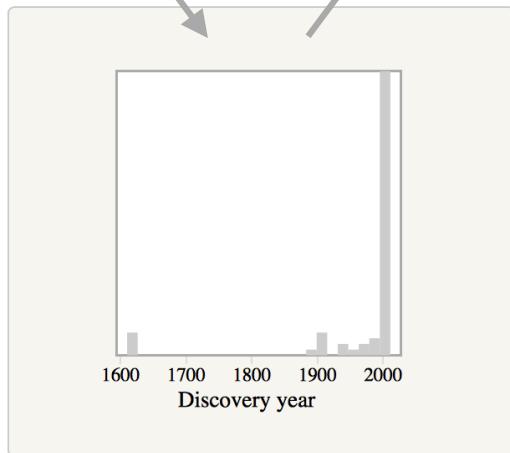

- Four Centuries of Discovery
- A Chasm in Mass
- Little Siblings
- Close Cousins
- The Strangers

After Galileo discovered the first four moons of Jupiter, it took nearly three hundred years to discover the next one.



[demo] [video]

Many thanks to Alberto Pepe, Josh Peek, Chris Beaumont, Tom Robitaille, Adrian Price-Whelan, Elizabeth Newton, Michelle Borkin & Matteo Cantiello for making this possible.

1610



SIDEREUS NUNCIVS

On the third, at the seventh hour, the sequence. The eastern one was 1 minute, the closest western one 2 minutes; and the

10 minutes removed from this one. They were absolutely on the same straight line and of equal magnitude.

On the fourth, at the second hour, there were four stars around Jupiter, two to the east and two to the west, and arranged precisely

on a straight line, as in the adjoining figure. The easternmost was distant 3 minutes from the next one, while this one was 40 seconds from Jupiter; Jupiter was 4 minutes from the nearest western one, and this one 6 minutes from the westernmost one. Their magnitudes were nearly equal; the one closest to Jupiter appeared a little smaller than the rest. But at the seventh hour the eastern star was 30 seconds apart, Jupiter was 2 minutes from the

one, while he was 4 minutes from the next western one was 3 minutes from the westernmost one. They and extended on the same straight line along the ecliptic.

On the fifth, the sky was cloudy.

On the sixth, only two stars appeared flanking Jupiter

in the adjoining figure. The eastern one was 2 minutes from the next western one 3 minutes from Jupiter. They were on the line with Jupiter and equal in magnitude.

On the seventh, two stars stood near Jupiter, both arranged in this manner.

East * O * West

East * O * West

East * O * West

East * O * West

East * O * West

4 Centuries from Galileo to Galileo

1665



1895

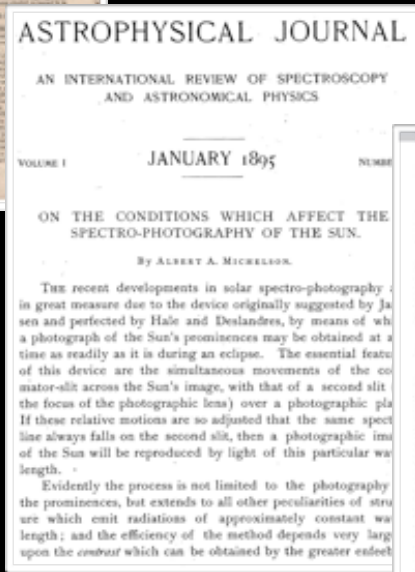

2009



2015

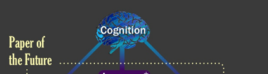

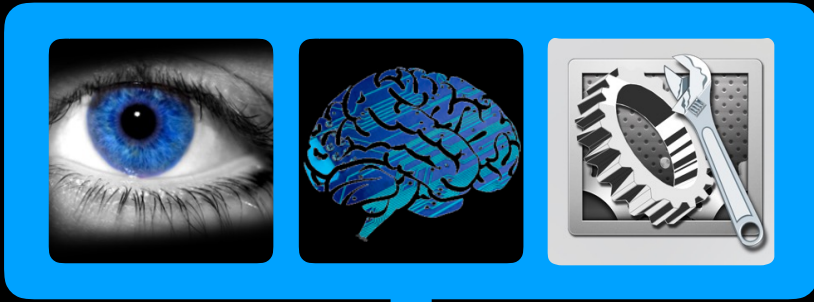

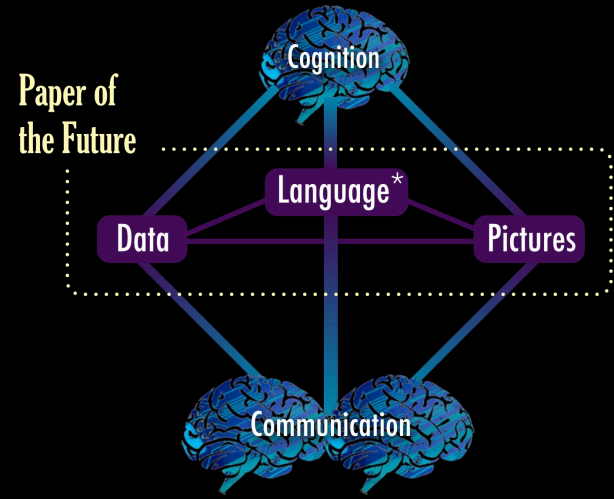
$$F = \frac{Gm_1m_2}{R^2}$$

Big DATA
versus
Wide DATA

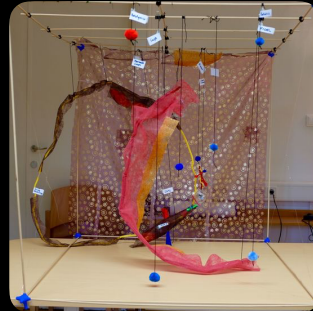
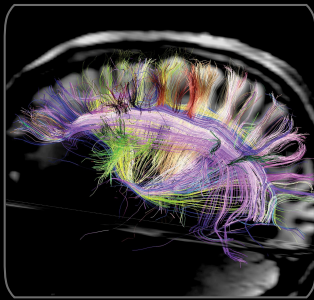
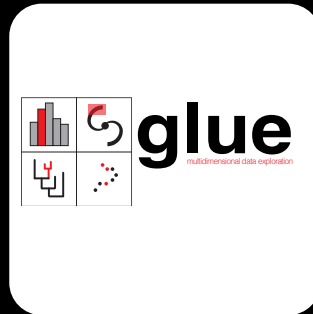
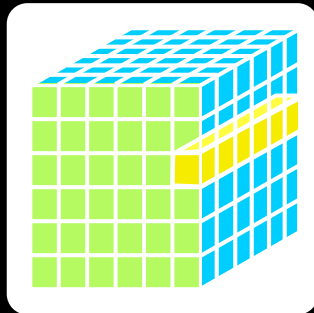
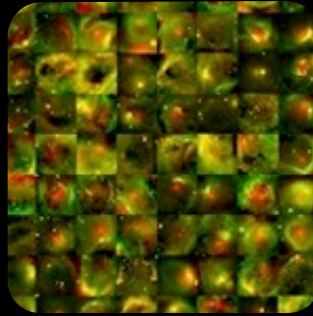

Big DATA
versus
Wide DATA

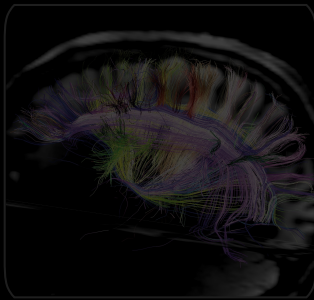
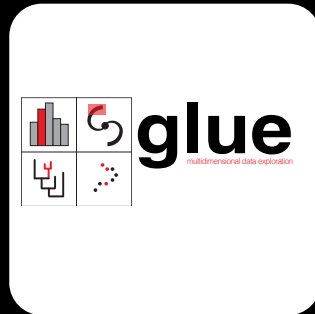
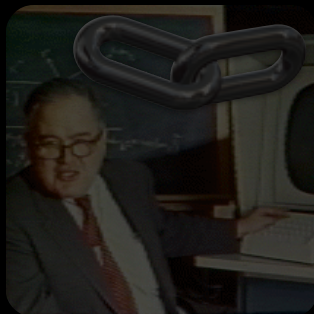
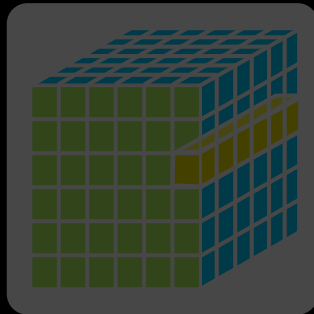
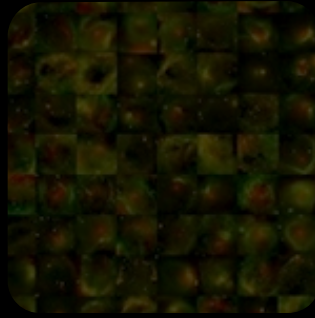

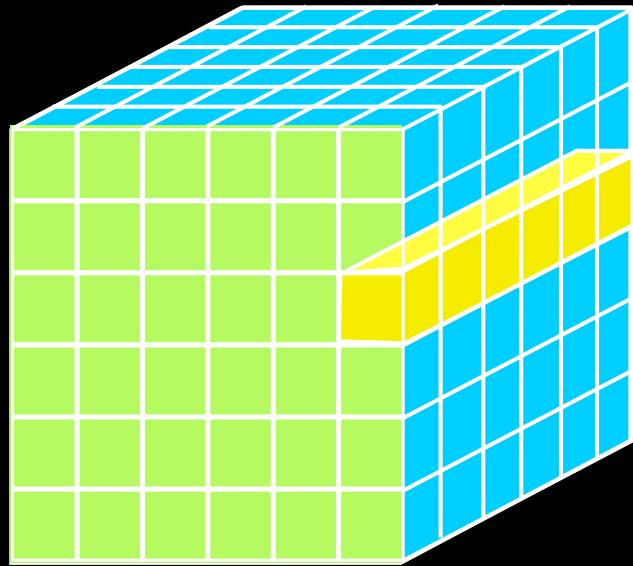
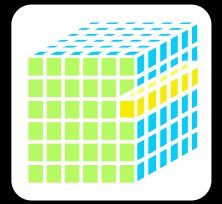

Data, Dimensions, Display

1D: Columns = "Spectra", "SEDs" or "Time Series"

2D: Faces or Slices = "Images"

3D: Volumes = "3D Renderings", "2D Movies"

4D: Time Series of Volumes = "3D Movies"

Data, Dimensions, Display

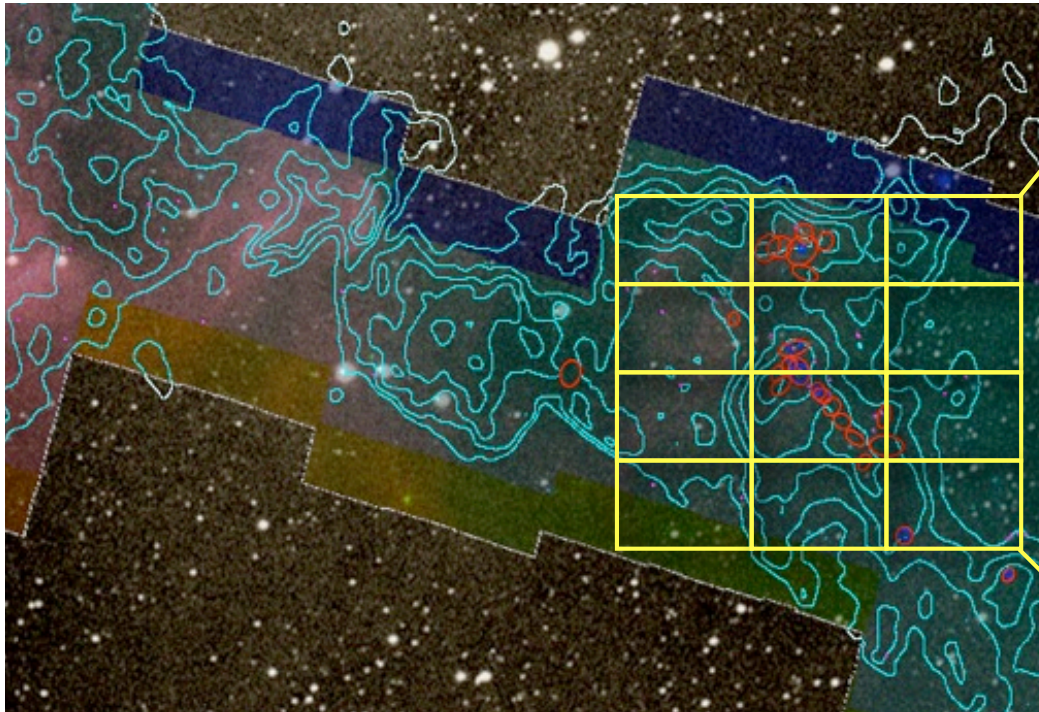
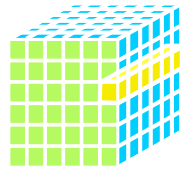

Spectral Line Observations

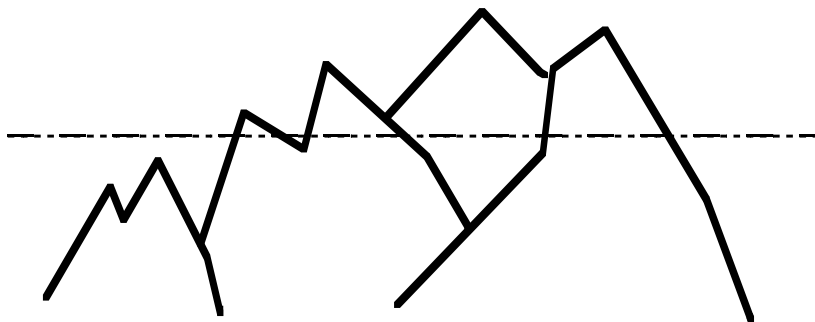
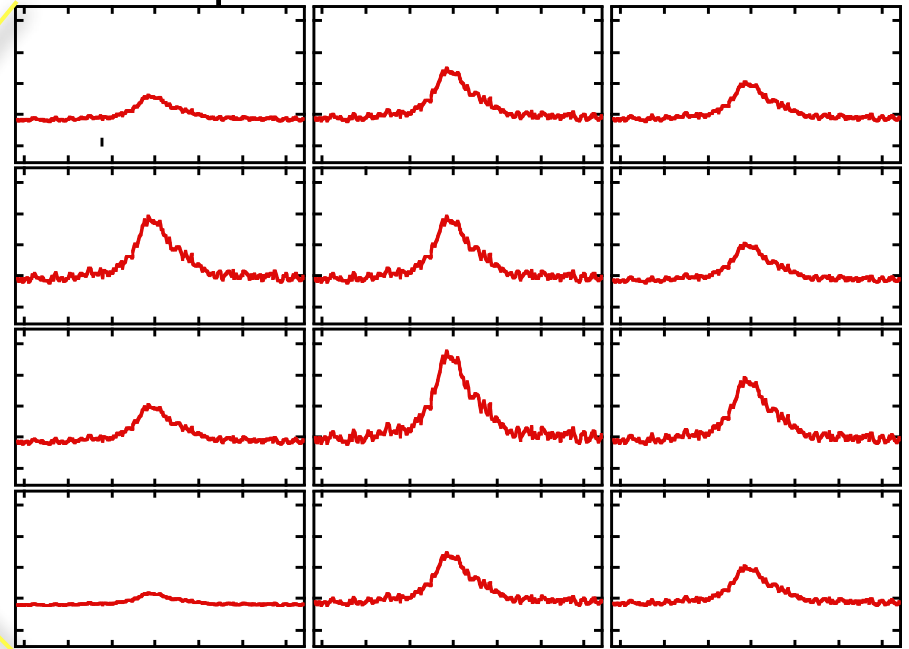

Mountain Range



No loss of information





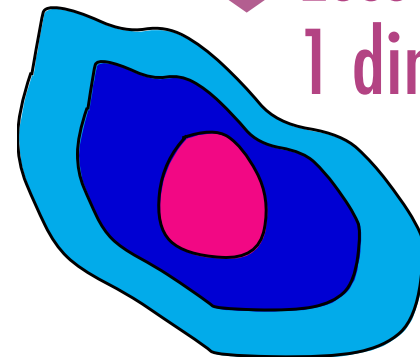

Loss of 1 dimension



Data, Dimensions, Display

VL: 63 WW: 127



-  mm peak (Enoch et al. 2006)
-  sub-mm peak (Hatchell et al. 2005, Kirk et al. 2006)
-  ^{13}CO (Ridge et al. 2006)
-  mid-IR IRAC composite from c2d data (Foster, Laakso, Ridge, et al.)
-  Optical image (Barnard 1927)

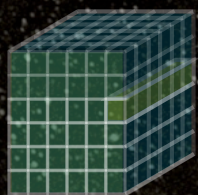

m: 1/249
Zoom: 227% Angle: 0



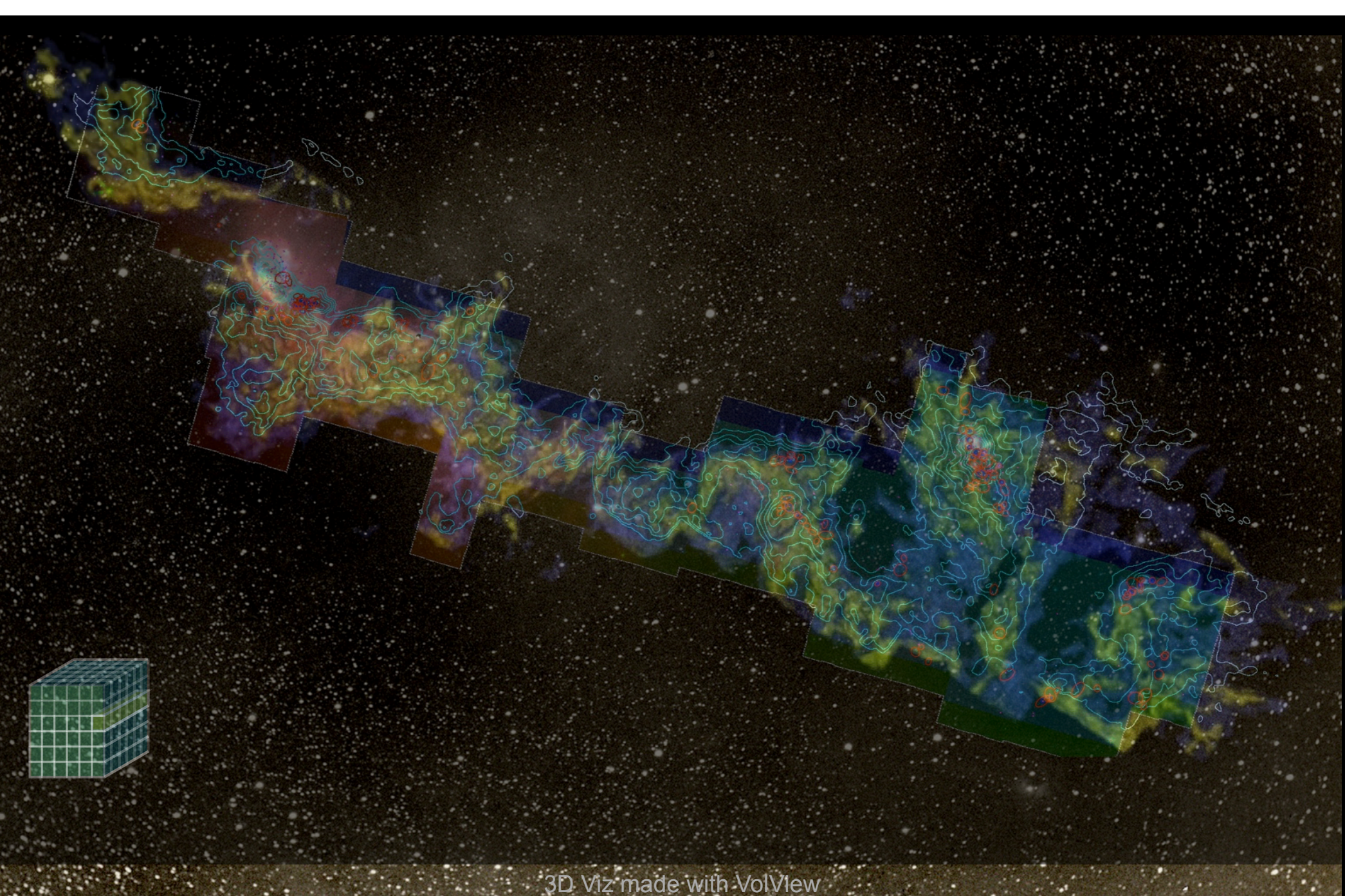

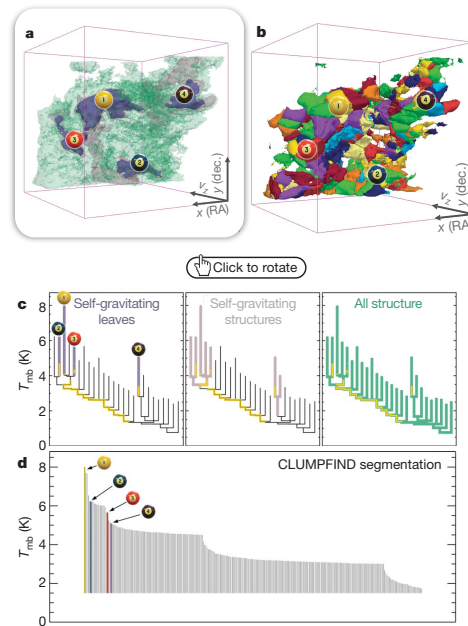

Figure 2 | Comparison of the 'dendrogram' and 'CLUMPFIND' feature-identification algorithms as applied to ^{13}CO emission from the L1448 region of Perseus. **a**, 3D visualization of the surfaces indicated by colours in the dendrogram shown in **c**. Purple illustrates the smallest scale self-gravitating structures in the region corresponding to the leaves of the dendrogram; pink shows the smallest surfaces that contain distinct self-gravitating leaves within them; and green corresponds to the surface in the data cube containing all the significant emission. Dendrogram branches corresponding to self-gravitating objects have been highlighted in yellow over the range of T_{mb} (main-beam temperature) test-level values for which the virial parameter is less than 2. The x - y locations of the four 'self-gravitating' leaves labelled with billiard balls are the same as those shown in Fig. 1. The 3D visualizations show position-position-velocity (p - p - v) space. RA, right ascension; dec., declination. For comparison with the ability of dendrograms (**c**) to track hierarchical structure, **d** shows a pseudo-dendrogram of the CLUMPFIND segmentation (**b**), with the same four labels used in Fig. 1 and in **a**. As 'clumps' are not allowed to belong to larger structures, each pseudo-branch in **d** is simply a series of lines connecting the maximum emission value in each clump to the threshold value. A very large number of clumps appears in **b** because of the sensitivity of CLUMPFIND to noise and small-scale structure in the data. In the online PDF version, the 3D cubes (**a** and **b**) can be rotated to any orientation, and surfaces can be turned on and off (interaction requires Adobe Acrobat version 7.0.8 or higher). In the printed version, the front face of each 3D cube (the 'home' view in the interactive online version) corresponds exactly to the patch of sky shown in Fig. 1, and velocity with respect to the Local Standard of Rest increases from front (-0.5 km s^{-1}) to back (8 km s^{-1}).

data, CLUMPFIND typically finds features on a limited range of scales, above but close to the physical resolution of the data, and its results can be overly dependent on input parameters. By tuning CLUMPFIND's two free parameters, the same molecular-line data set⁸ can be used to show either that the frequency distribution of clump mass is the same as the initial mass function of stars or that it follows the much shallower mass function associated with large-scale molecular clouds (Supplementary Fig. 1).

Four years before the advent of CLUMPFIND, 'structure trees'⁹ were proposed as a way to characterize clouds' hierarchical structure

using 2D maps of column density. With the help of 2D work as inspiration, we have developed a structure-identification algorithm that abstracts the hierarchical structure of a data set into an easily visualized representation called a dendrogram. Well developed in other data-intensive fields, the application of tree methodologies so far has been almost exclusively within the astronomical domain, where 'merger trees' are being used with increasing frequency.

Figure 3 and its legend explain the dendrogram process schematically. The dendrogram quantifies the hierarchy of emission merge with each other, as explained in Supplementary Methods. The dendrogram is determined almost entirely by the sensitivity to algorithm parameters, which can be varied as possible on paper and 2D screen data (see Fig. 3 and its legend), which eliminates dimensions, preserving all information. Numbered 'billiard ball' labels identify key features between a 2D map and a sorted dendrogram.

A dendrogram of a spectrum of key physical properties, such as radius (R), surface area (A), luminosity (L). The volumes can have any shape, and the significance of the especially elongated features is quantified (Fig. 2a). The luminosity is an approximate proxy for mass, such that $M_{\text{lum}} = X_{13\text{CO}} L_{13\text{CO}}$, where $X_{13\text{CO}} = 8.0 \times 10^{20} \text{ cm}^{-2} \text{ K}^{-1} \text{ km}^{-1} \text{ s}$ (ref. 15; see Supplementary Methods and Supplementary Fig. 2). The derived values for size, mass and velocity dispersion can then be used to estimate the role of self-gravity at each point in the hierarchy, via calculation of an 'observed' virial parameter, $\alpha_{\text{obs}} = 5\sigma_v^2 R/GM_{\text{lum}}$. In principle, extended portions of the tree (Fig. 2, yellow highlighting) where $\alpha_{\text{obs}} < 2$ (where gravitational energy is comparable to or larger than kinetic energy) correspond to regions of p - p - v space where self-gravity is significant. As α_{obs} only represents the ratio of kinetic energy to gravitational energy at one point in time, and does not explicitly capture external over-pressure and/or magnetic fields¹⁶, its measured value should only be used as a guide to the longevity (boundedness) of any particular feature.

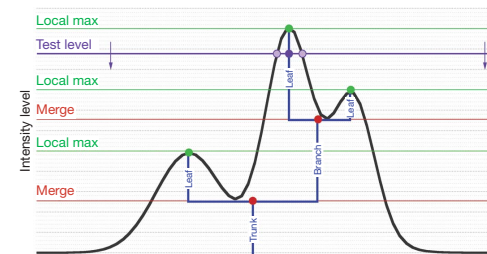
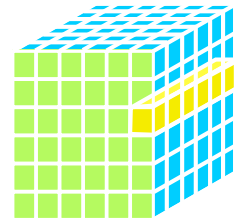

Figure 3 | Schematic illustration of the dendrogram process. Shown is the construction of a dendrogram from a hypothetical one-dimensional emission profile (black). The dendrogram (blue) can be constructed by 'dropping' a test constant emission level (purple) from above in tiny steps (exaggerated in size here, light lines) until all the local maxima and mergers are found, and connected as shown. The intersection of a test level with the emission is a set of points (for example the light purple dots) in one dimension, a planar curve in two dimensions, and an isosurface in three dimensions. The dendrogram of 3D data shown in Fig. 2c is the direct analogue of the tree shown here, only constructed from 'isosurface' rather than 'point' intersections. It has been sorted and flattened for representation on a flat page, as fully representing dendrograms for 3D data cubes would require four dimensions.



Goodman et al. 2009, Nature, cf: Fluke et al. 2009

2009
3D PDF
High-Dimensional
data in a
"Paper"
on its way
to the Future

[demo/video]

LETTERS

A role for self-gravity at multiple length scales in the process of star formation

Alyssa A. Goodman^{1,2}, Erik W. Rosolowsky^{2,3}, Michelle A. Borkin^{1†}, Jonathan B. Foster², Michael Halle^{1,4}, Jens Kauffmann^{1,2} & Jaime E. Pineda²

Self-gravity plays a decisive role in the final stages of star formation, where dense cores (size ~ 0.1 parsecs) inside molecular clouds collapse to form star-plus-disk systems¹. But self-gravity's role at earlier times (and on larger length scales, such as ~ 1 parsec) is unclear; some molecular cloud simulations that do not include self-gravity suggest that 'turbulent fragmentation' alone is sufficient to create a mass distribution of dense cores that resembles, and sets, the stellar initial mass function². Here we report a 'dendrogram' (hierarchical tree-diagram) analysis that reveals that self-gravity plays a significant role over the full range of possible scales traced by ¹³CO observations in the L1448 molecular cloud, but not everywhere in the observed region. In particular, more than 90 per cent of the compact 'pre-stellar cores' traced by peaks of dust emission³ are projected on the sky within one of the dendrogram's self-gravitating 'leaves'. As these peaks mark the locations of already-forming stars, or of those probably about to form, a self-gravitating cocoon seems a critical condition for their exist-

overlapping features as an option, significant emission found between prominent clumps is typically either appended to the nearest clump or turned into a small, usually 'pathological', feature needed to encompass all the emission being modelled. When applied to molecular-line

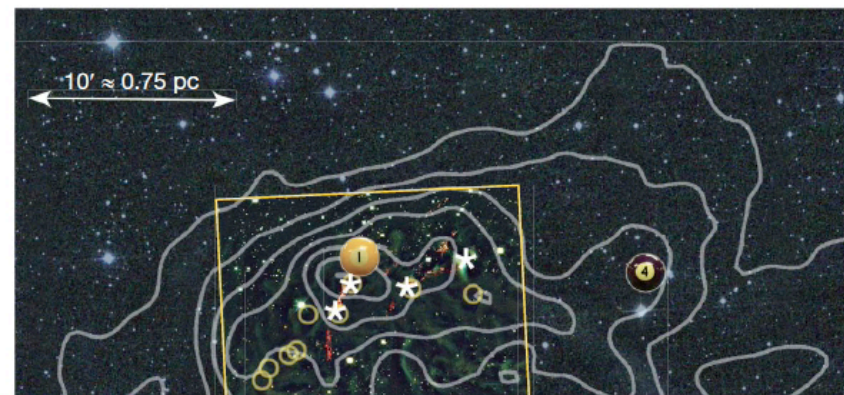

Why Astronomical **Medicine**?

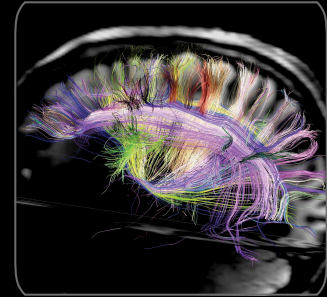

"KEITH"

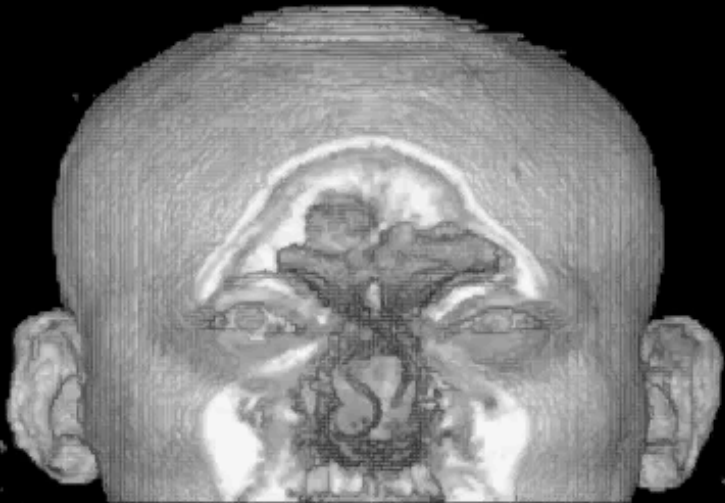

"z" is depth into head

"PERSEUS"

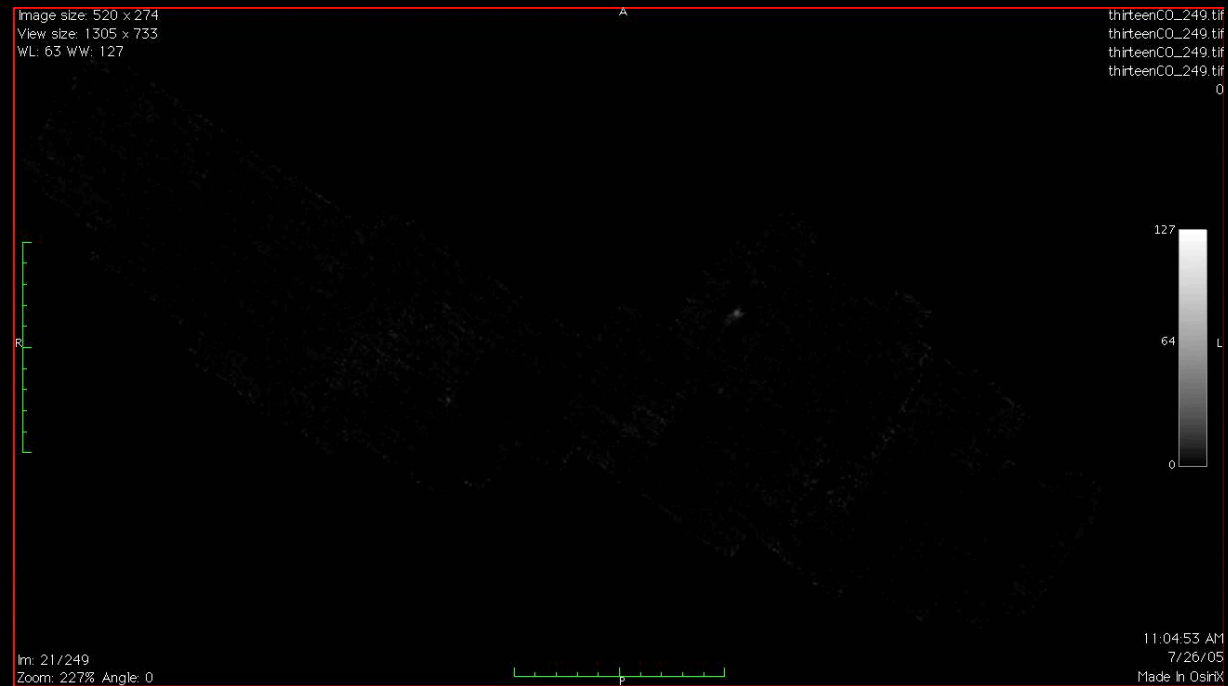

"z" is line-of-sight velocity

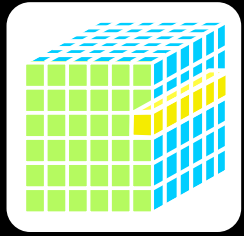

Why Astronomical**Medicine**?



Big DATA
versus
Wide DATA

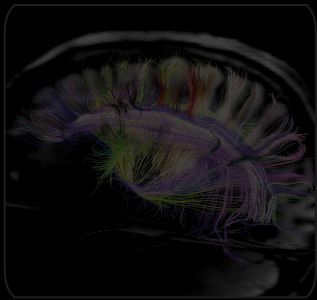
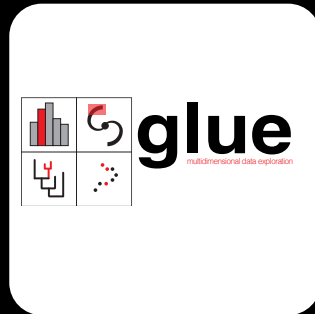
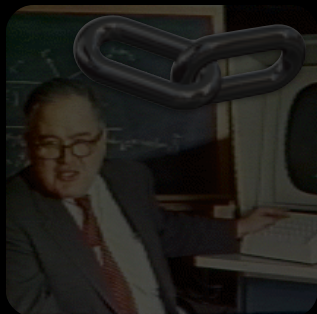
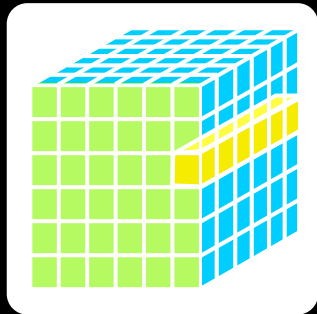
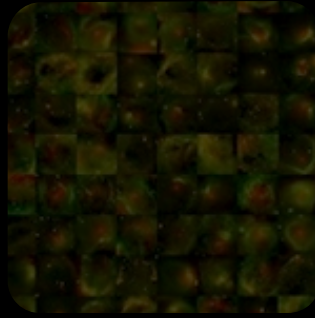



WIDE DATA



COMPLETE

 mm peak (Enoch et al. 2006)

 sub-mm peak (Hatchell et al. 2005, Kirk et al. 2006)

 ^{13}CO (Ridge et al. 2006)

 mid-IR IRAC composite from c2d data (Foster, Laakso, Ridge, et al.)

 Optical image (Barnard 1927)

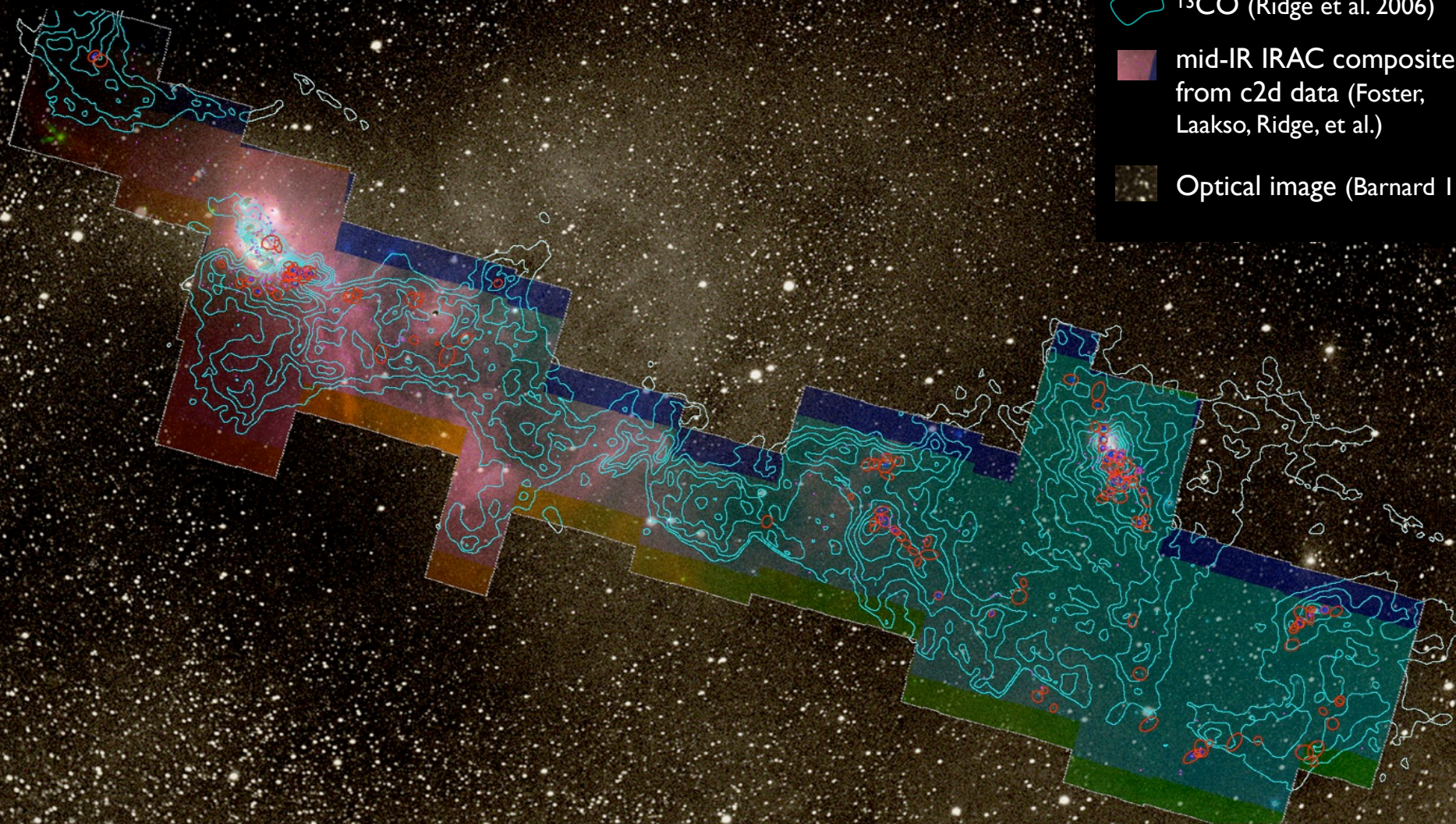

WIDE DATA

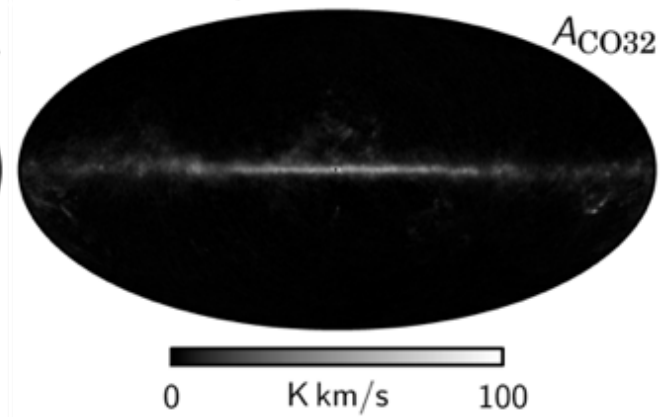
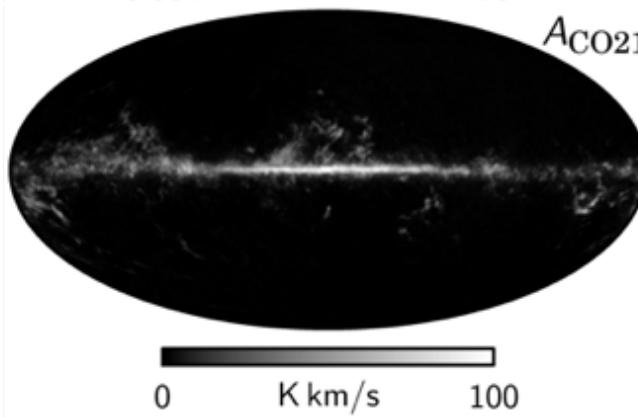
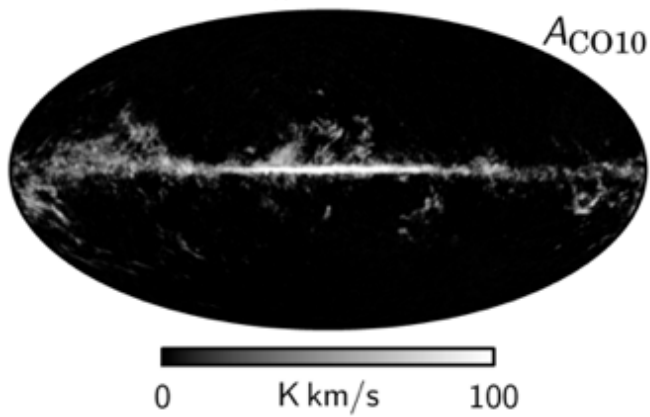
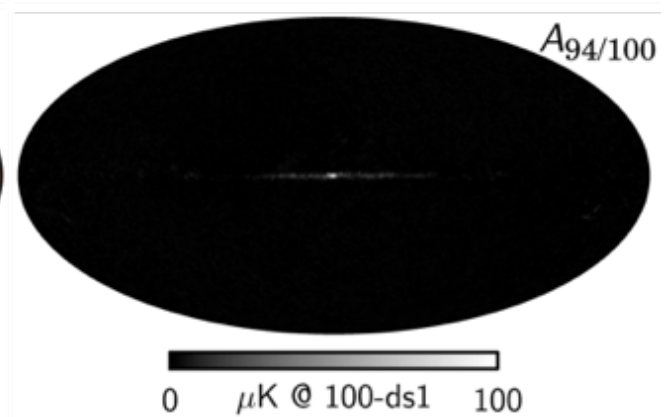
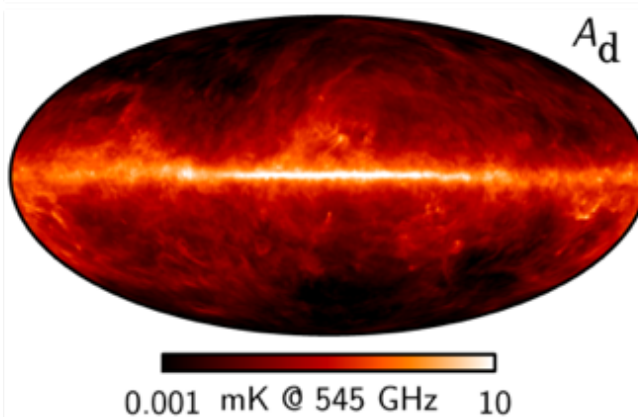
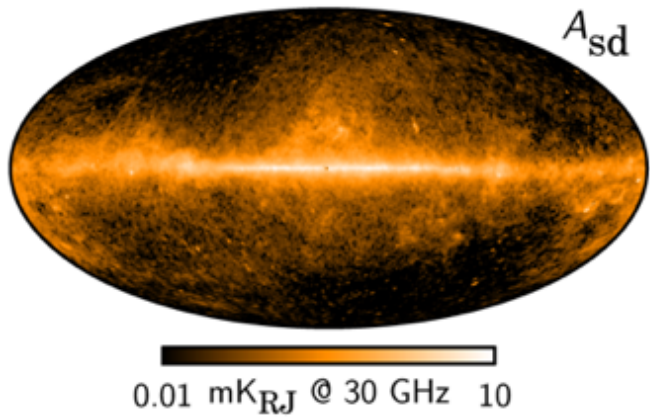
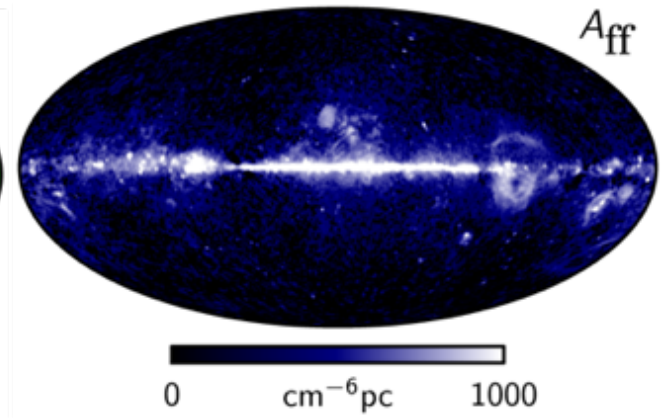
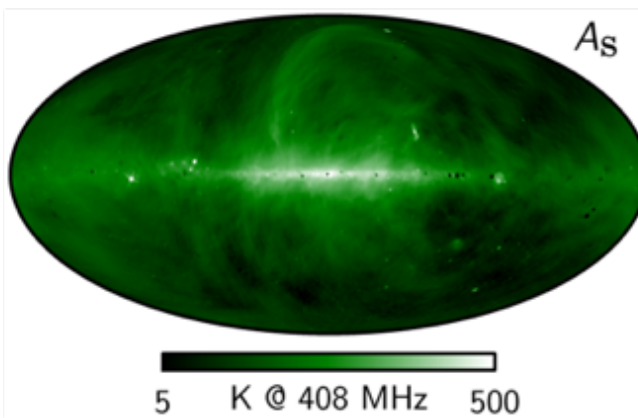
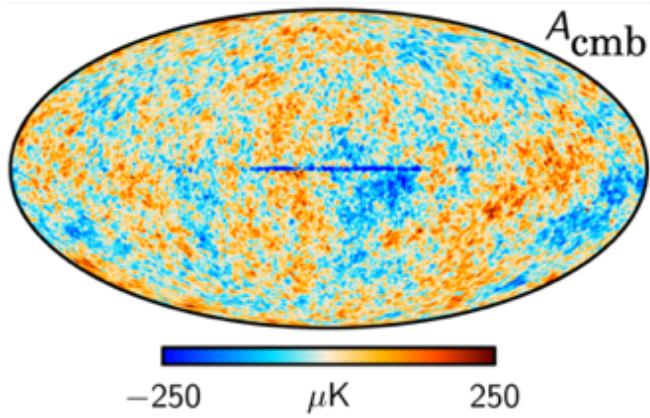

Use Layer Manager to Control User Settings

Name My Location
Lat 37:47:15 Alt 0 m
Lng -123:35:23
View From This Location

2015/02/11 04:40:33
Real Time
Now

Galactic Plane Mode

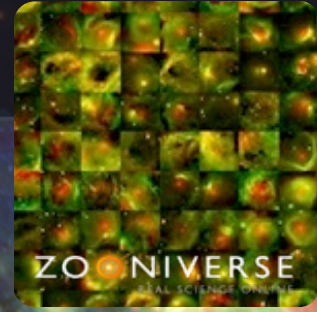

BIG DATA

Look At Sky Imagery Digitized Sky Survey (Color) Image Crossfade

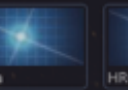
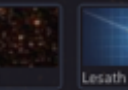

Tracking GLIMPSE/MIPSGAL

1 of 3



Scorpius 03:10:14



BIG DATA AND "HUMAN-AIDED COMPUTING"

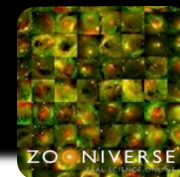

THE MILKY WAY PROJECT ZO NIVERSE REAL SCIENCE ONLINE

mark bubbles

What do you see in this image?

Bubble Star Cluster EGO Galaxy Object I'm done!

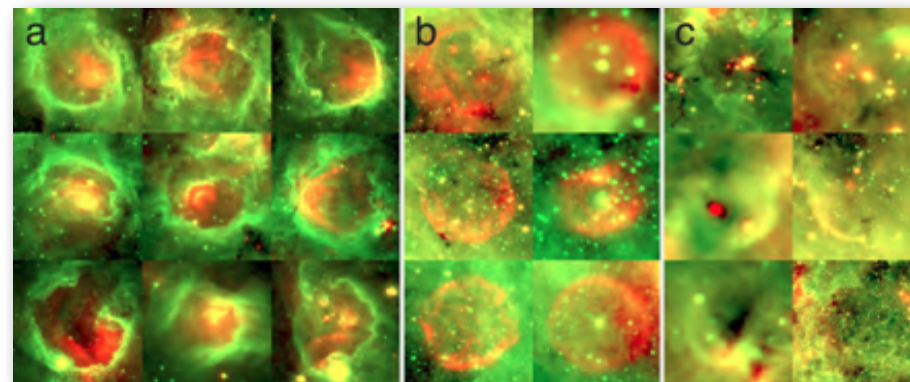

machine-learning algorithm (Brut)

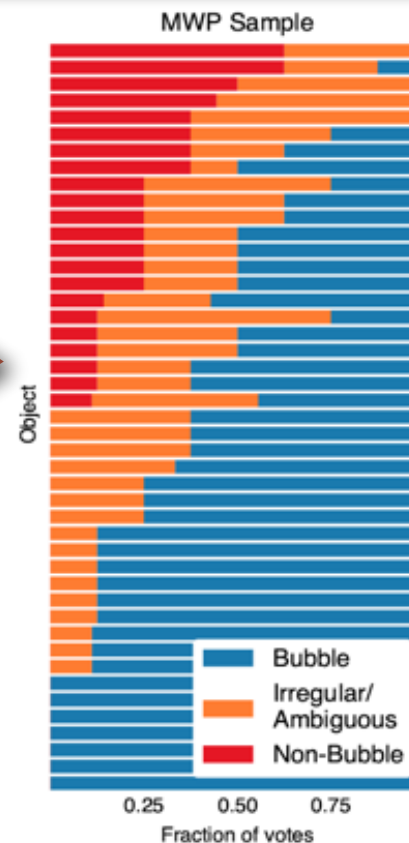
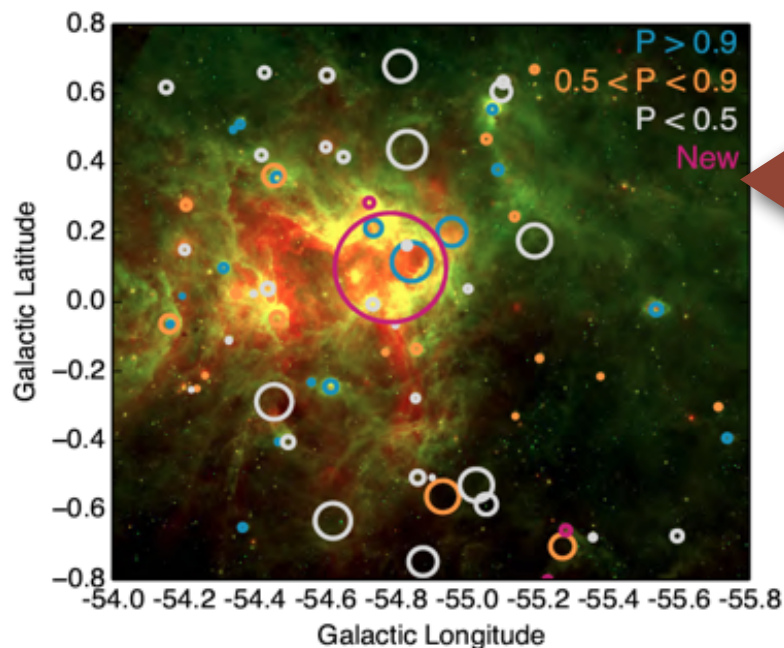

example here from: **Beaumont**, Goodman, Kendrew, Williams & Simpson 2014; based on **Milky Way Project** catalog (Simpson et al. 2013), which came from **Spitzer/GLIMPSE** (Churchwell et al. 2009, Benjamin et al. 2003), cf. Shenoy & Tan 2008 for discussion of HAC; astroml.org for machine learning advice/tools

BIG DATA AND "HUMAN-AIDED COMPUTING"

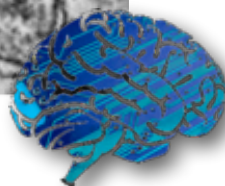
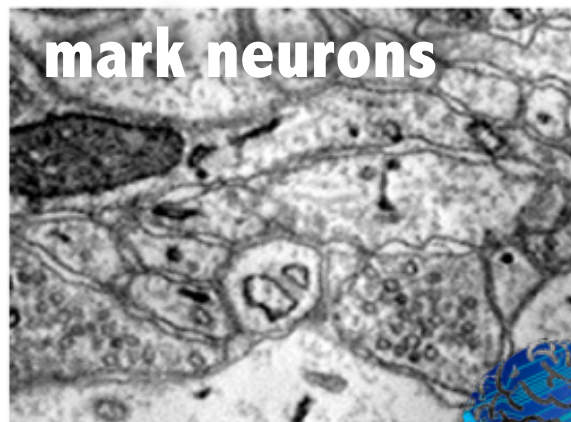
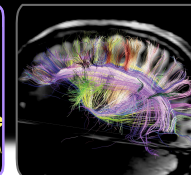

**machine-learning
algorithm
(RF+CRF)**

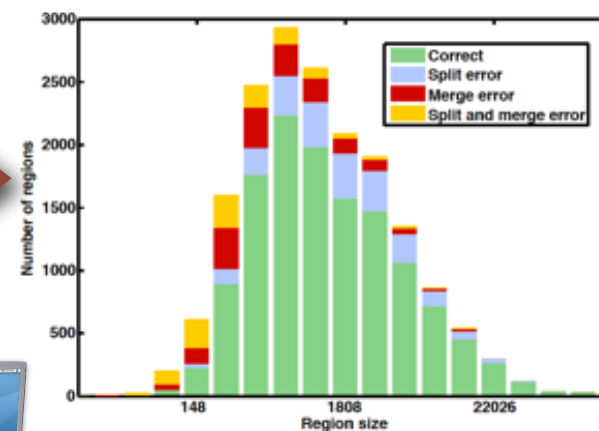
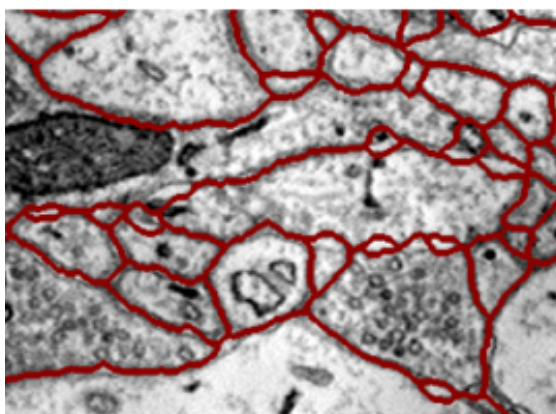

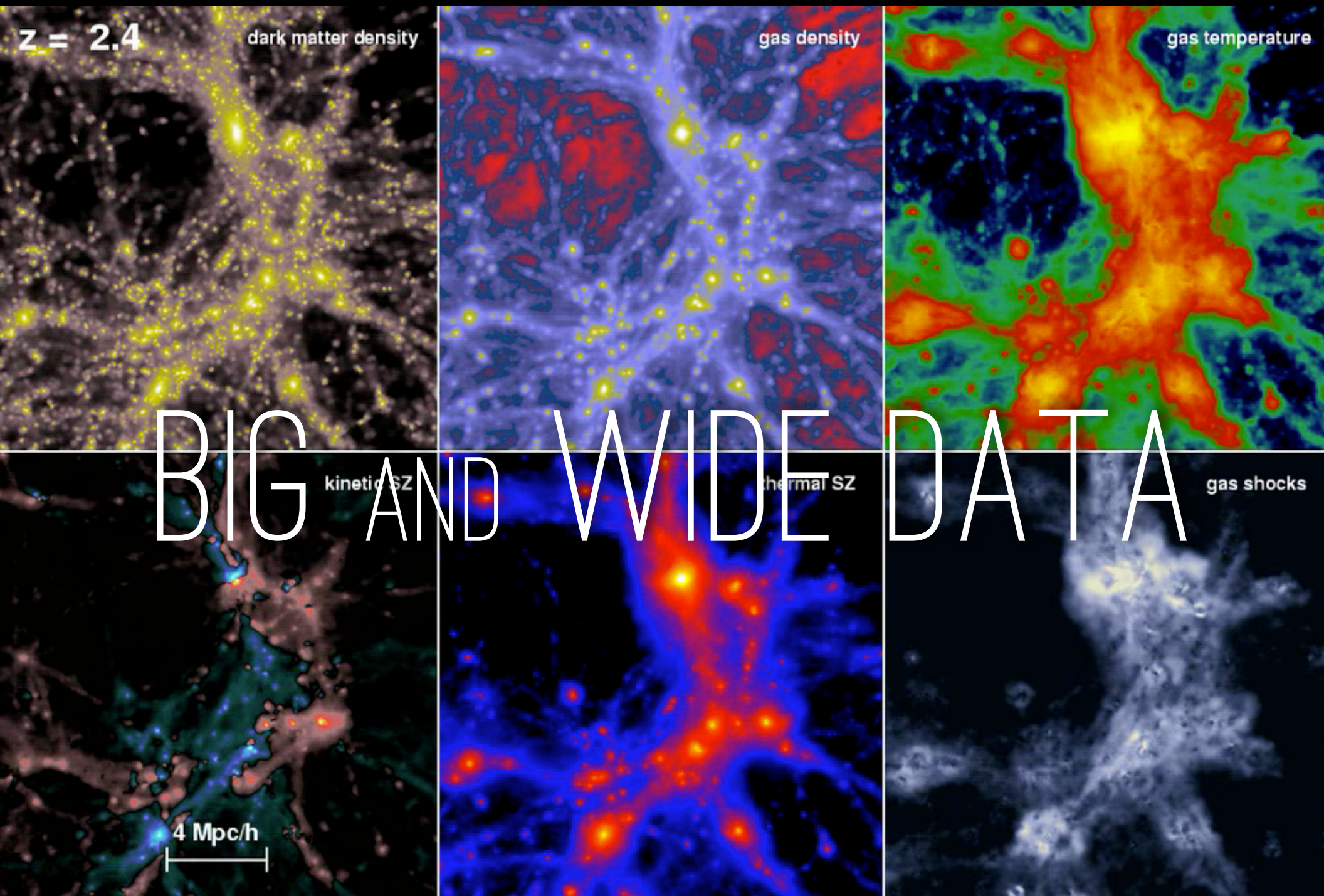

Movie: Volker Springel, formation of a cluster of galaxies. Millenium Simulation requires 25TB for output.

Big DATA
versus
Wide DATA

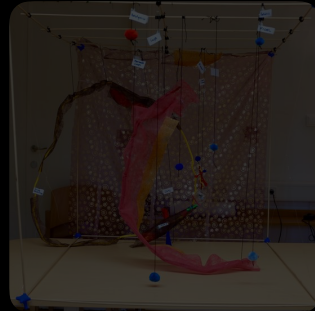
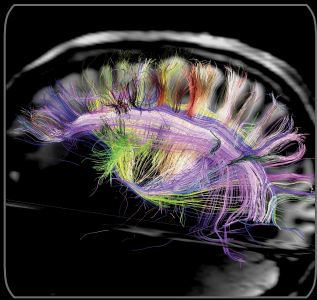
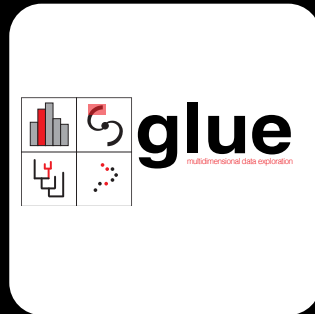
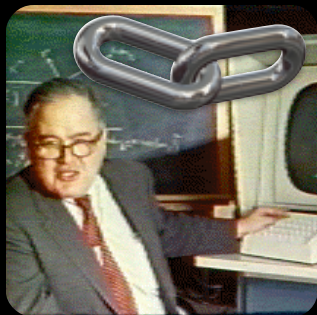
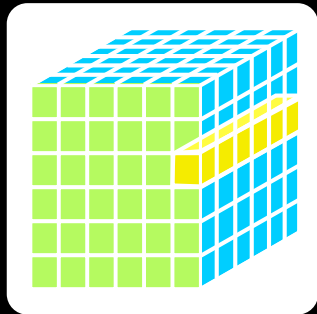
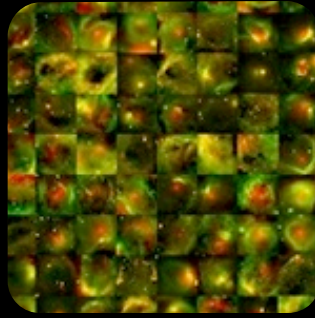

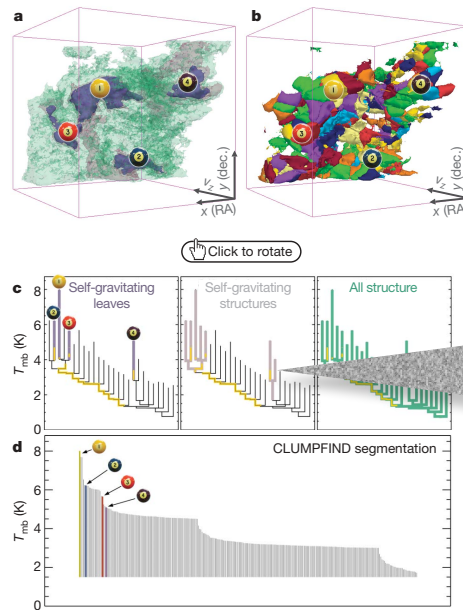

Figure 2 | Comparison of the 'dendrogram' and 'CLUMPFIND' feature-identification algorithms as applied to ^{13}CO emission from the L1448 region of Perseus. **a**, 3D visualization of the surfaces indicated by colours in the dendrogram shown in **c**. Purple illustrates the smallest scale self-gravitating structures in the region corresponding to the leaves of the dendrogram; pink shows the smallest surfaces that contain distinct self-gravitating leaves within them; and green corresponds to the surface in the data cube containing all the significant emission. Dendrogram branches corresponding to self-gravitating objects have been highlighted in yellow over the range of T_{mb} (main-beam temperature) test-level values for which the virial parameter is less than 2. The x - y locations of the four 'self-gravitating' leaves labelled with billiard balls are the same as those shown in Fig. 1. The 3D visualizations show position-position-velocity (p - p - v) space. RA, right ascension; dec., declination. For comparison with the ability of dendrograms (**c**) to track hierarchical structure, **d** shows a pseudo-dendrogram of the CLUMPFIND segmentation (**b**), with the same four labels used in Fig. 1 and in **a**. As 'clumps' are not allowed to belong to larger structures, each pseudo-branch in **d** is simply a series of lines connecting the maximum emission value in each clump to the threshold value. A very large number of clumps appears in **b** because of the sensitivity of CLUMPFIND to noise and small-scale structure in the data. In the online PDF version, the 3D cubes (**a** and **b**) can be rotated to any orientation, and surfaces can be turned on and off (interaction requires Adobe Acrobat version 7.0.8 or higher). In the printed version, the front face of each 3D cube (the 'home' view in the interactive online version) corresponds exactly to the patch of sky shown in Fig. 1, and velocity with respect to the Local Standard of Rest increases from front (-0.5 km s^{-1}) to back (8 km s^{-1}).

data, CLUMPFIND typically finds features on a limited range of scales, above but close to the physical resolution of the data, and its results can be overly dependent on input parameters. By tuning CLUMPFIND's two free parameters, the same molecular-line data set⁸ can be used to show either that the frequency distribution of clump mass is the same as the initial mass function of stars or that it follows the much shallower mass function associated with large-scale molecular clouds (Supplementary Fig. 1).

Four years before the advent of CLUMPFIND, 'structure trees'⁹ were proposed as a way to characterize clouds' hierarchical structure

using 2D maps of column density. With the help of the 2D work as inspiration, we have developed a structure-identifying algorithm that abstracts the hierarchical structure of a data cube into an easily visualized representation called a dendrogram. Well developed in other data-intensive fields, dendrograms have application of tree methodologies so far as they go, and almost exclusively within the astronomy community. 'merger trees' are being used with increasing frequency. Figure 3 and its legend explain the dendrogram process schematically. The dendrogram construction

THESE ARE
"DEAD"
PANELS!
THAT'S NOT
GOOD
ENOUGH.

used to estimate the role of self-gravity at each point in the hierarchy, via calculation of an 'observed' virial parameter, $\alpha_{\text{obs}} = 5\sigma^2 R/GM_{\text{clump}}$. In principle, extended portions of the tree (Fig. 2, yellow highlighting) where $\alpha_{\text{obs}} < 2$ (where gravitational energy is comparable to or larger than kinetic energy) correspond to regions of p - p - v space where self-gravity is significant. As α_{obs} only represents the ratio of kinetic energy to gravitational energy at one point in time, and does not explicitly capture external over-pressure and/or magnetic fields¹⁶, its measured value should only be used as a guide to the longevity (boundedness) of any particular feature.

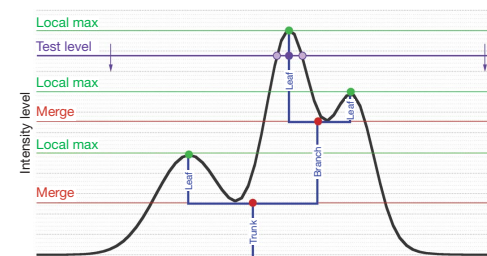
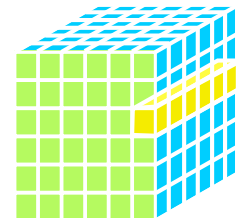

Figure 3 | Schematic illustration of the dendrogram process. Shown is the construction of a dendrogram from a hypothetical one-dimensional emission profile (black). The dendrogram (blue) can be constructed by 'dropping' a test constant emission level (purple) from above in tiny steps (exaggerated in size here, light lines) until all the local maxima and mergers are found, and connected as shown. The intersection of a test level with the emission is a set of points (for example the light purple dots) in one dimension, a planar curve in two dimensions, and an isosurface in three dimensions. The dendrogram of 3D data shown in Fig. 2c is the direct analogue of the tree shown here, only constructed from 'isosurface' rather than 'point' intersections. It has been sorted and flattened for representation on a flat page, as fully representing dendrograms for 3D data cubes would require four dimensions.



Goodman et al. 2009, Nature, cf: Fluke et al. 2009

2009
3D PDF
High-Dimensional
data in a
"Paper"
on its way
to the Future

Linked Views of High-dimensional Data



John Tukey

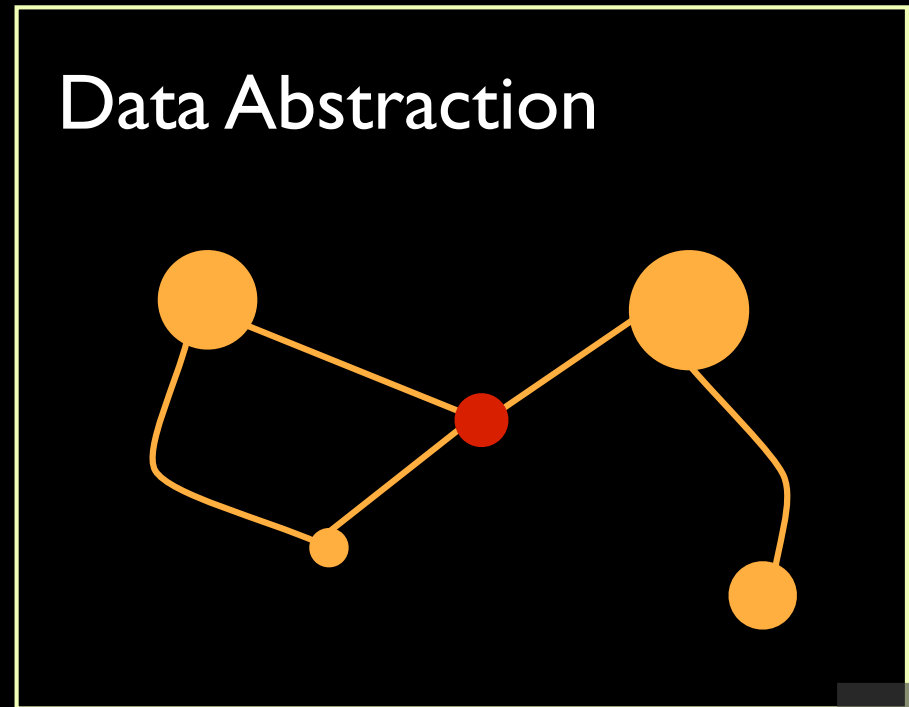
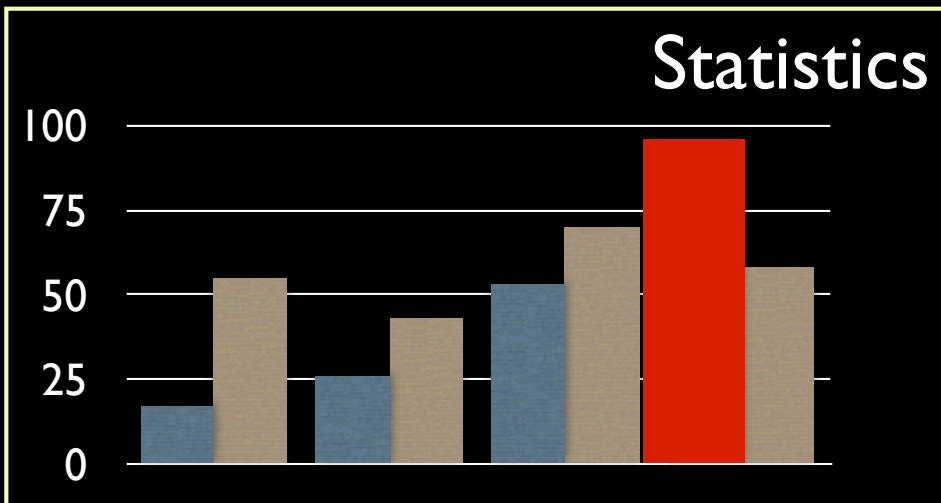
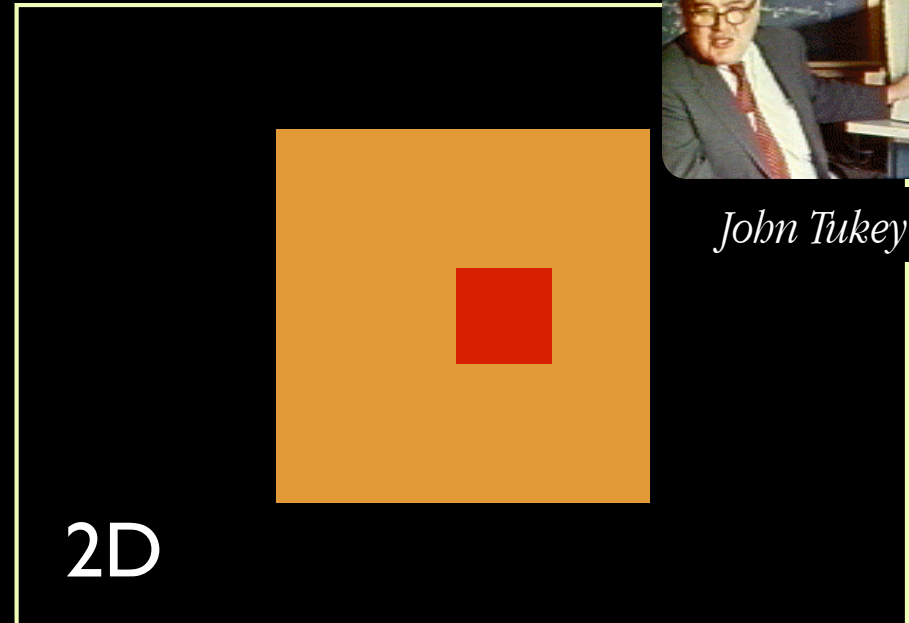
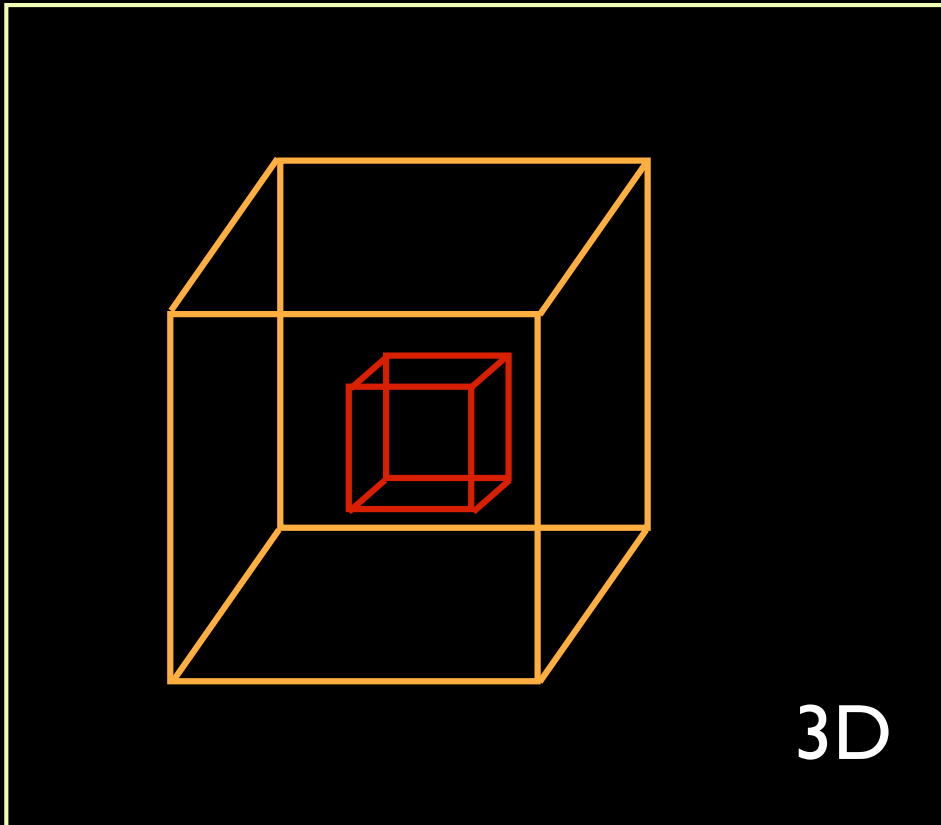

JOHN TUKEY'S LEGACY



PRIM-9

PRIM-H

DataDesk®

XGobi

GGobi

RGGobi

Spotfire®

Polaris

+tableau
SOFTWARE

glue
enhanced & complete

1970

1980

1990

2000

2010

LINKED VIEWS OF HIGH-DIMENSIONAL DATA (IN PYTHON)

GLUE

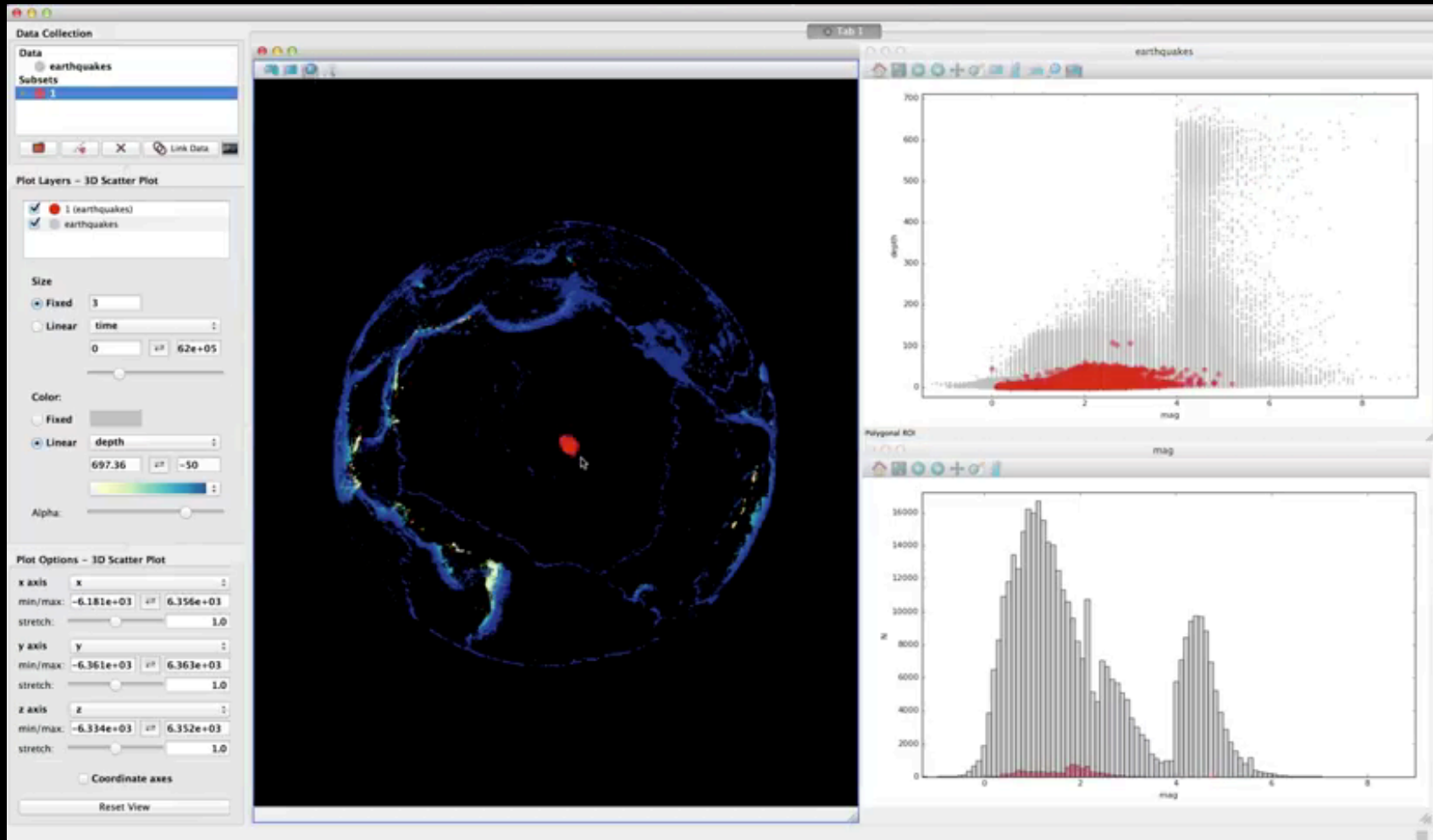
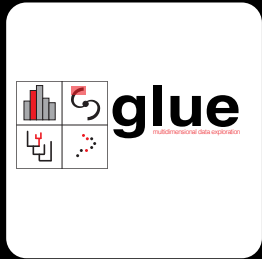

*video by Tom Robitaille, lead glue developer
glue created by: C. Beaumont, M. Borkin, P. Qian, T. Robitaille, and A. Goodman, PI*

LINKED VIEWS OF HIGH-DIMENSIONAL DATA (IN PYTHON) GLUE

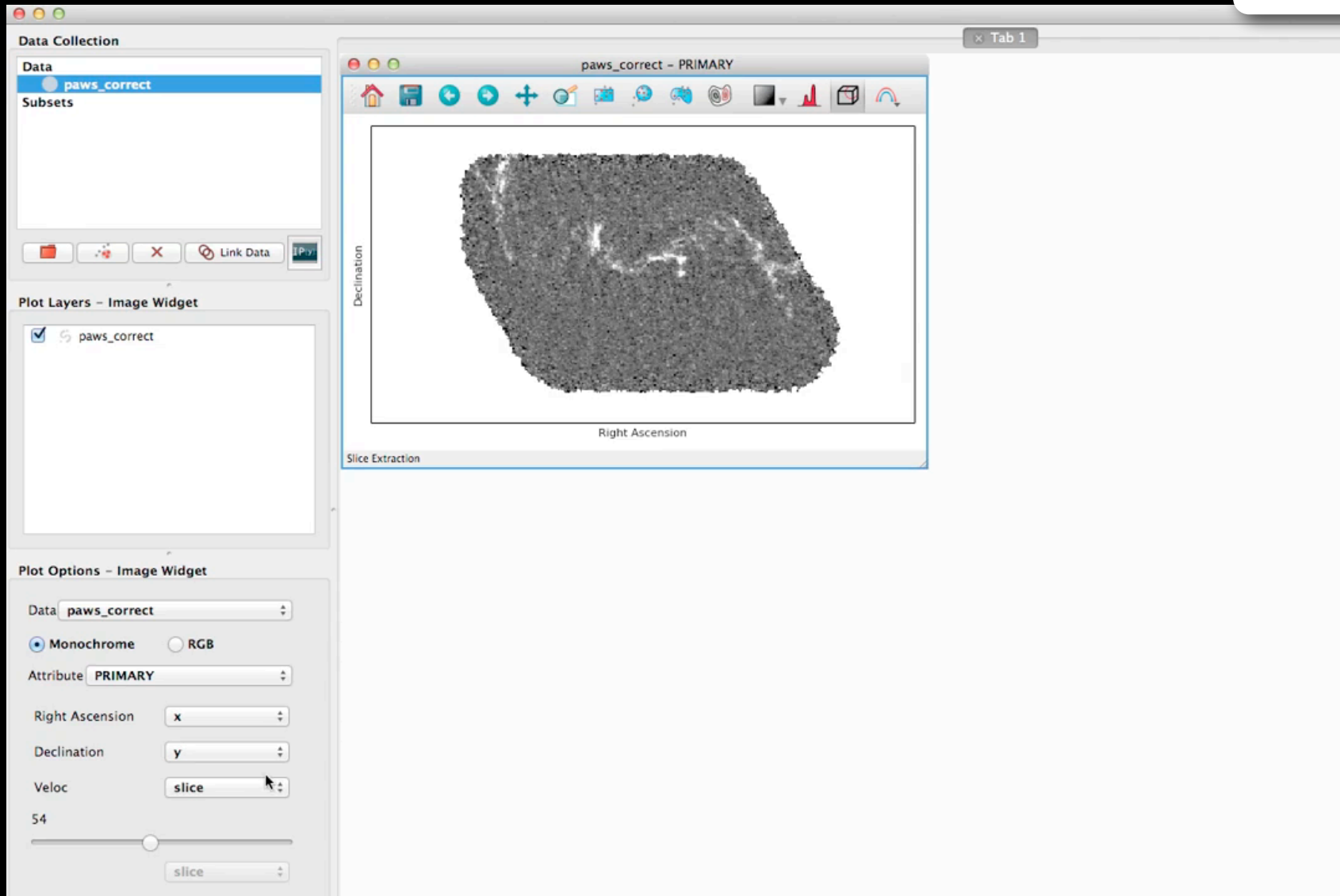

video by Chris Beaumont, glue developer
glue created by: C. Beaumont, M. Borkin, P. Qian, T. Robitaille, and A. Goodman, PI



your handout

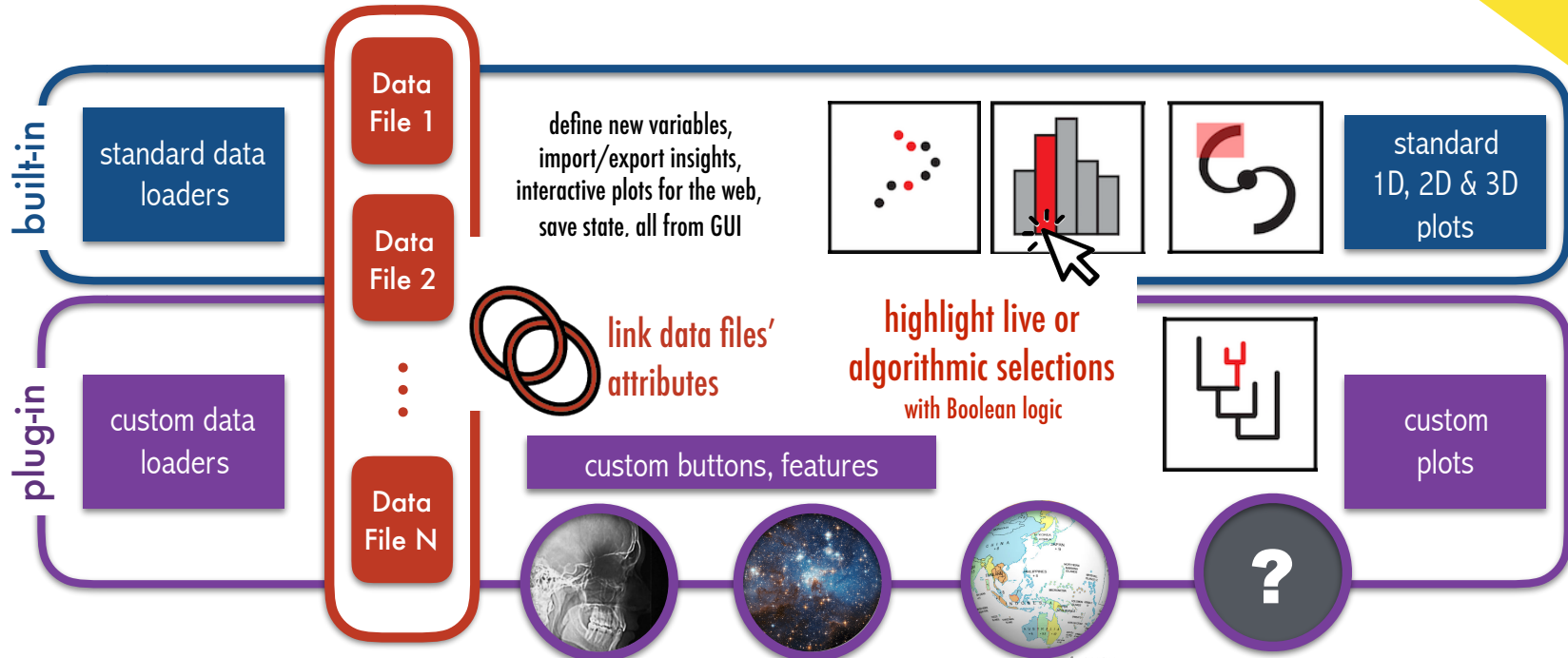

+options

user config.py file (loaders, colors, plot types, +)



access to all matplotlib functions through built-in IPython terminal



run & interact with glue from Jupyter notebook & other tools

glueviz.org

What is visualization (and all this software) for?

INSIGHT

CONTEXT

Spatial

Non-Spatial

PATTERN RECOGNITION

Ideas

Outliers

EVALUATION

Algorithms

Errors

GLUEING TOGETHER THE MILKY WAY

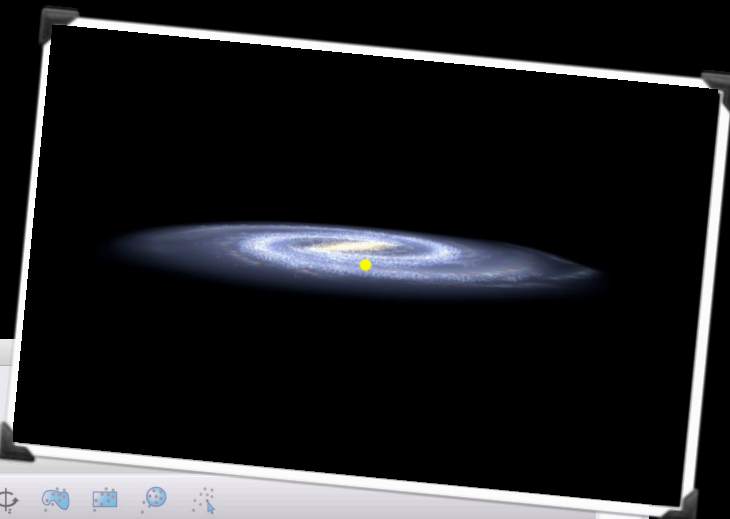

Selection Mode:

- HOPS_ammonia_catalog_ICRS
- Nessie_13CO_ThrUMMS_slab
- Nessie_GLIMPSE_8micron_cropped
- Nessie_HIGAL_Column_Density(PRIMA...

Subsets

- Nessie
- Nessie (HOPS_ammonia_catalog_I...
- Nessie (Nessie_13CO_ThrUMMS_sl...
- Nessie (Nessie_GLIMPSE_8micron_...
- Nessie (Nessie_HIGAL_Column_De...

Plot Layers - WorldWideTelescope (WWT)

- Nessie (HOPS_ammonia_catalog_ICRS)
- HOPS_ammonia_catalog_ICRS

Color:

Size: 3

Opacity:

RA: ra

Dec: dec

Center view on layer

Plot Options - WorldWideTelescope (WWT)

Foreground: IRIS: Improved Reprocessing

Opacity:

Background: Digitized Sky Survey (Color)

Galactic Plane mode

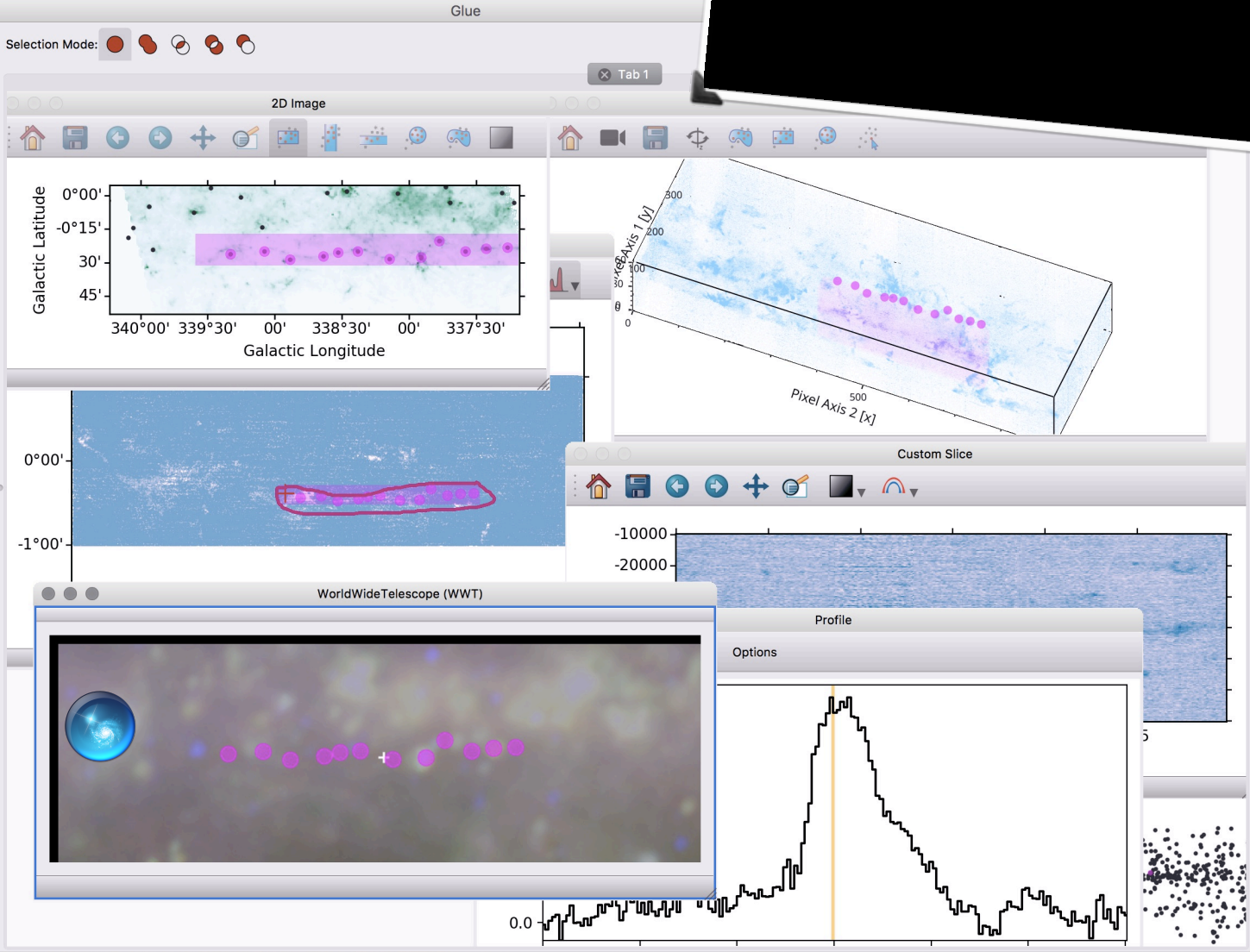

LOGAN AIRPORT (AND MY FBI FILE)



Terminal Open Session Save Session Add/edit data components Selection Mode: Preferences View Error Console

3D Scatter

2D Scatter

2D Image

2D Scatter

Sub

- nearground
- Descending
- Climbing
- Landing
- A Day in the Life of Logan

Plot Layers - 2D Scatter

- A Day in the Life of Logan (airplane_positions)
- Landing (airplane_positions)
- Climbing (airplane_positions)
- Descending (airplane_positions)
- nearground (airplane_positions)

Color Points Line Errors Vectors

color Fixed

opacity

Plot Options - 2D Scatter

General Limits Axes

x label: Heading (degrees)

y label: Ground Speed

axis label size: 10

axis label weight: medium

tick label size: 10

Apply to all plots



JUPYTER LAB: GLUE IN THE BROWSER

The screenshot displays the JupyterLab web interface. On the left, a code editor shows the command `app.scatter3d('x', 'y', 'z');` in a Python 3 environment. Below the code is a 3D scatter plot with axes labeled x, y, and z. The plot shows a distribution of points, with a subset highlighted in orange. On the right, an 'Output View' window shows a 2D scatter plot of the same data, with a 'brush x' tool active. In the center, a modal window titled 'Start a new activity' is open, offering three options: 'Notebook', 'Code Console', and 'Text Editor'. The background features a histogram of the data, with the x-axis labeled 'z' and the y-axis labeled 'Number'. The histogram bars are colored in a gradient from black to orange. A watermark in the bottom right corner reads 'Video courtesy of Maarten Breddels, consulting developer'. In the bottom left corner, there is a logo for 'glue in the browser' with the tagline 'multimedia data exploration'.

Video courtesy of Maarten Breddels, consulting developer

glue in the browser
multimedia data exploration

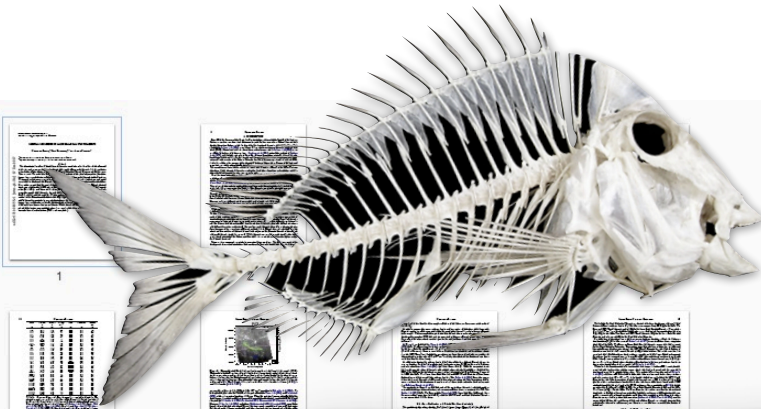

The Physical Properties of Large-Scale Galactic Filaments

Catherine Zucker, Cara Battersby, Alyssa Goodman

(Submitted on 27 Dec 2017)

The characterization of our Galaxy's longest filamentary gas features has been the subject of several studies in recent years, producing not only a sizeable sample of large-scale filaments, but also confusion as to whether all these features (e.g. "Bones", "Giant Molecular Filaments") are essentially the same. They are not. We undertake the first standardized analysis of the physical properties (densities, temperatures, morphologies, radial profiles) and kinematics of large-scale filaments in the literature. We expand and improve upon prior analyses by using the same data sets, techniques, and spiral arm models to disentangle the filaments' inherent properties from selection criteria and methodology. Our results suggest that the myriad filament finding techniques are uncovering different physical structures, with length (11–269 pc), width (1–40 pc), mass ($3 \times 10^3 M_{\odot} - 1.1 \times 10^6 M_{\odot}$), aspect ratio (3:1 – 117:1), and dense gas fraction (0.2–100%) varying by at least an order of magnitude across the sample of 45 filaments. As part of this analysis, we develop a radial profile fitting code, *RadFil*, which is publicly available. We also perform a *position – position – velocity* ($p - p - v$) analysis on a subset of the filaments and find that while 60%–70% lie in the plane of the Galaxy, only 30–45% also exhibit kinematic proximity to purported spiral arms. In a parameter space defined by aspect ratio, temperature, and density, we broadly distinguish three filament categories, which could be indicative of different formation mechanisms or histories. Highly elongated "Bone-like" filaments show the most potential for tracing gross spiral structure (e.g. arms), while other categories could simply be large concentrations of molecular gas (GMCs, core complexes).

Comments: Submitted to The Astrophysical Journal
Subjects: **Astrophysics of Galaxies (astro-ph.GA)**
Cite as: **arXiv:1712.09655 [astro-ph.GA]**
(or **arXiv:1712.09655v1 [astro-ph.GA]** for the first version)

Yes, more on this visualization challenge!

Nah, maybe later...

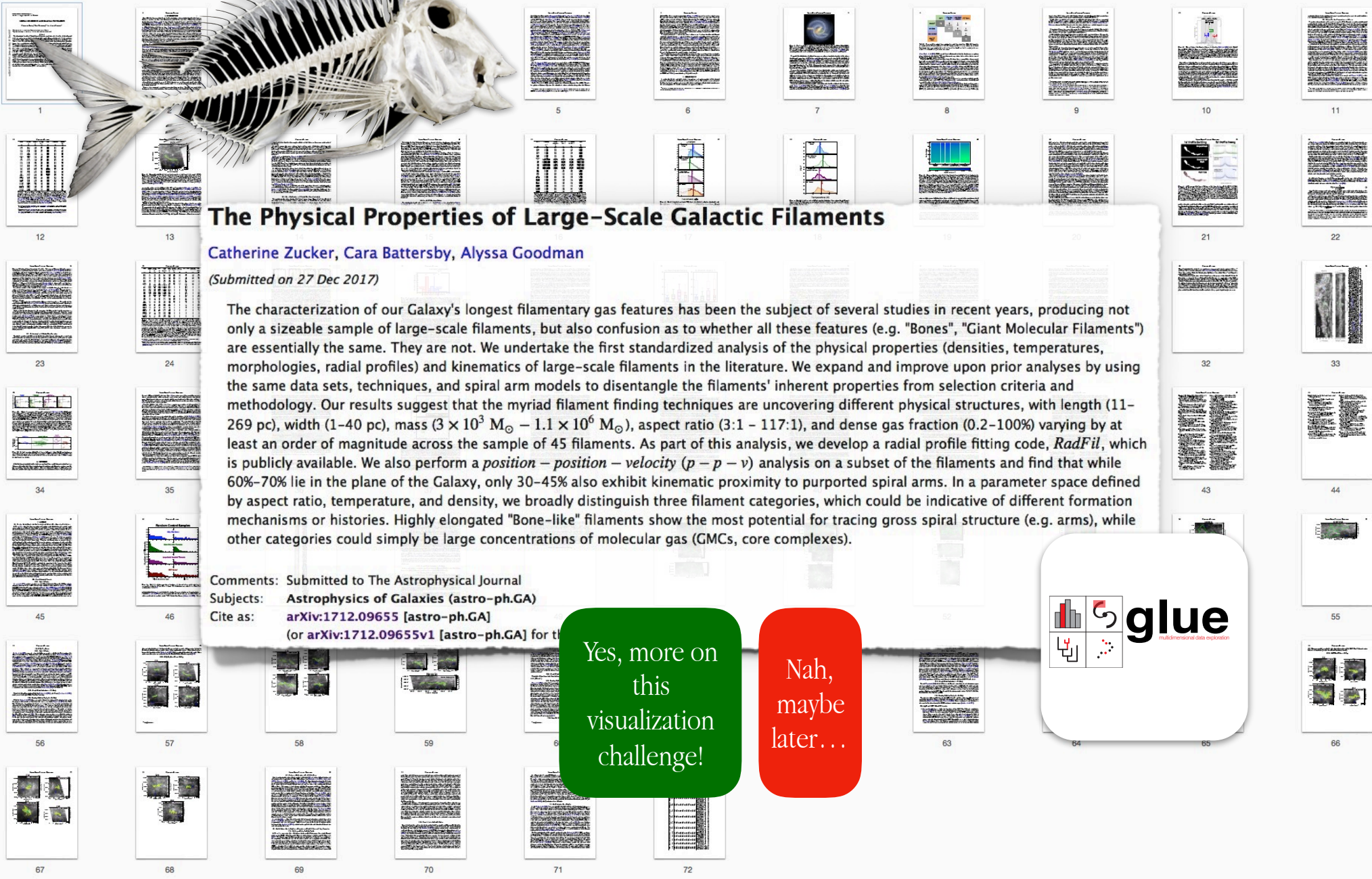

The Physical Properties of Large-Scale Galactic Filaments

a visualization saga...

Catherine Zucker, Cara Battersby, Alyssa Goodman

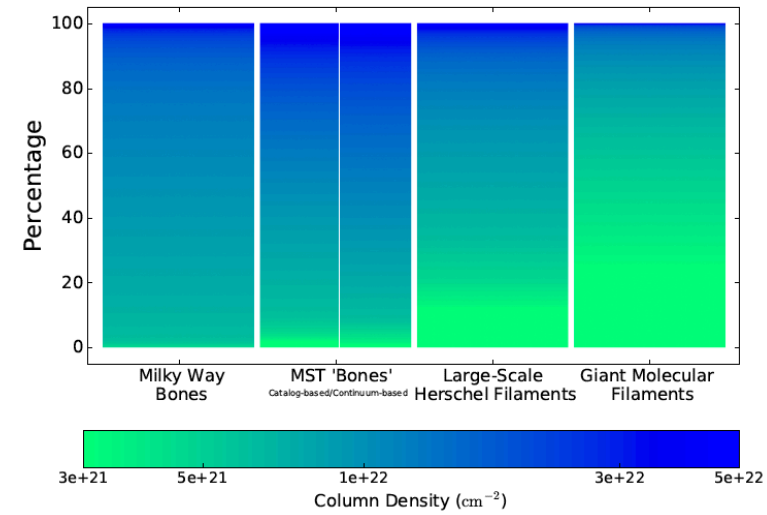
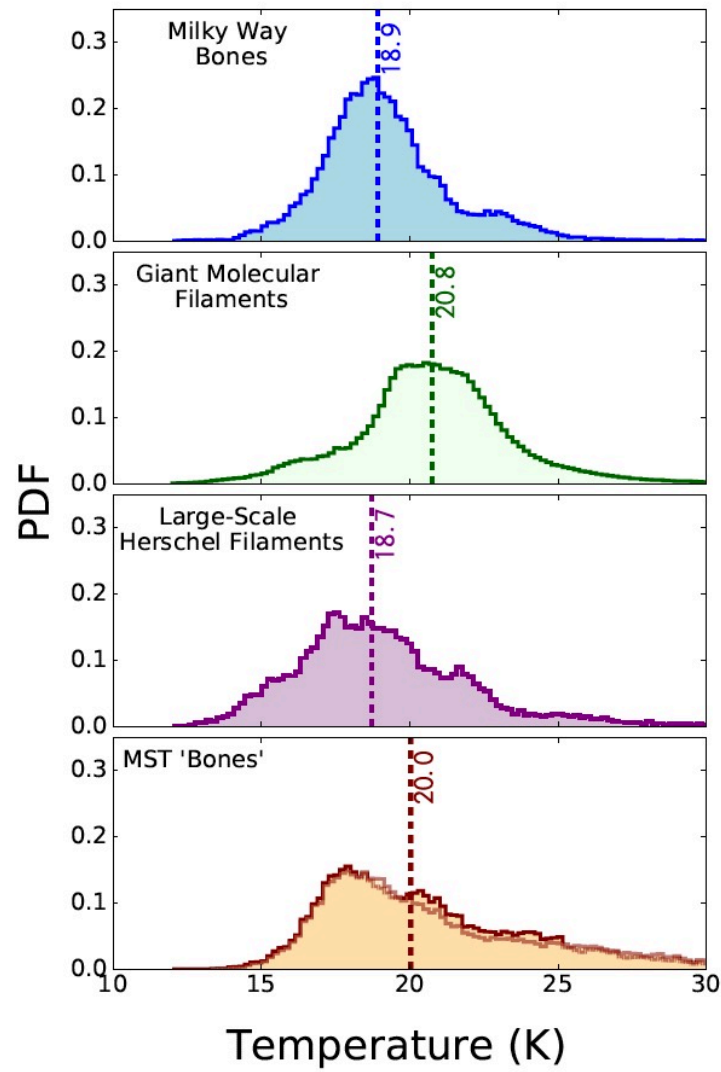
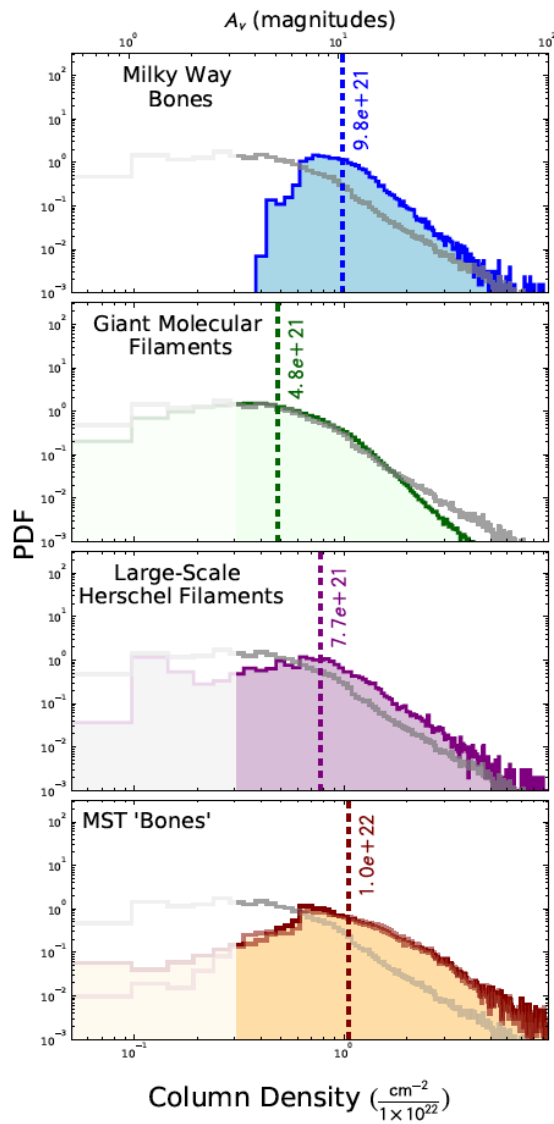

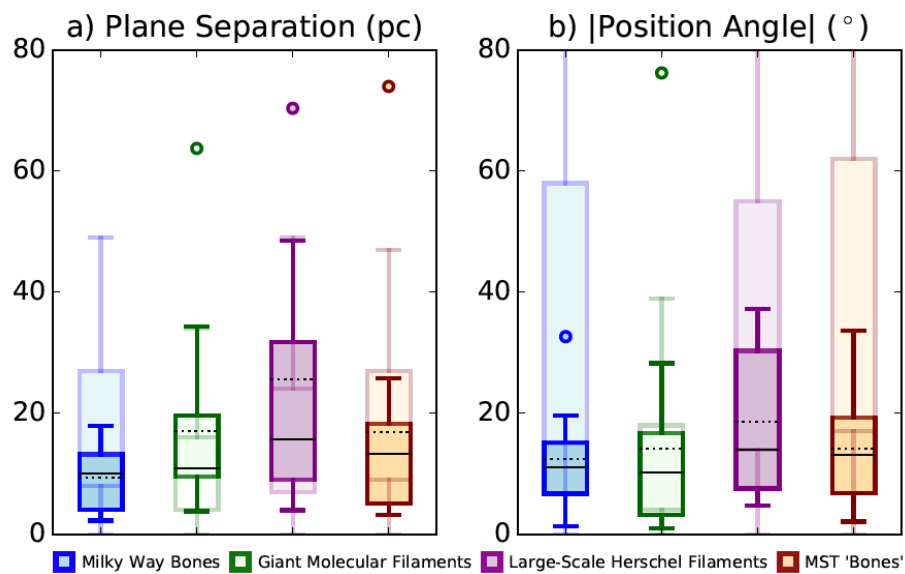
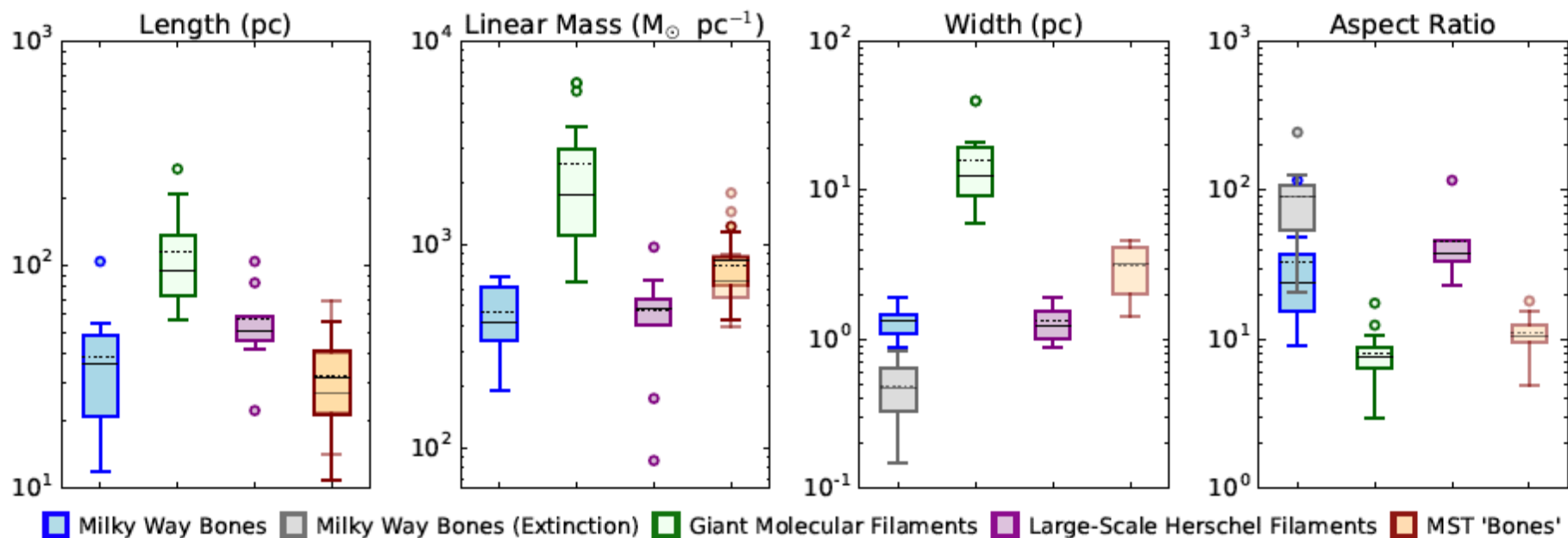

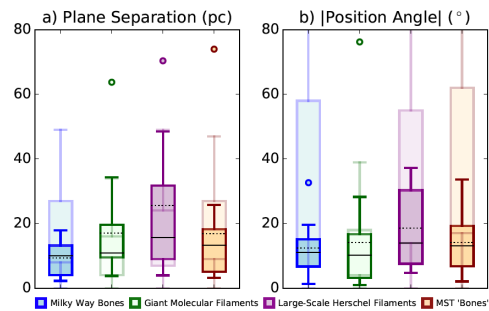
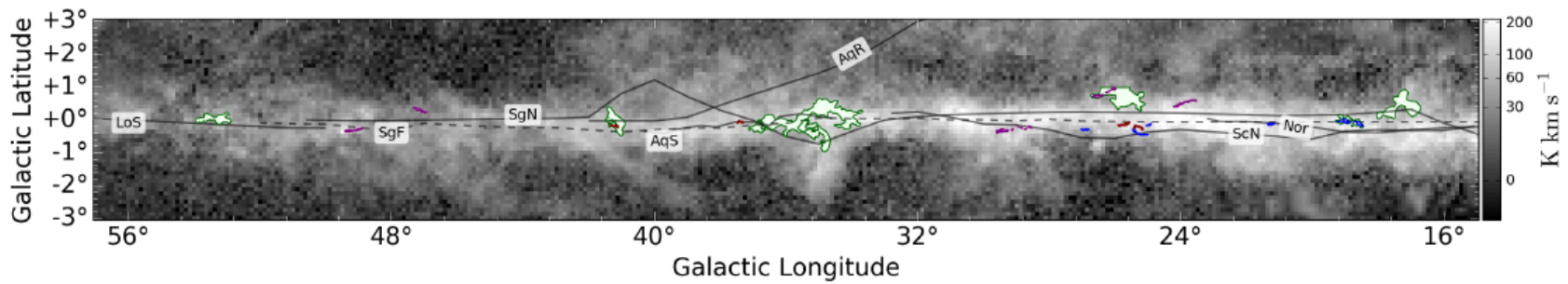
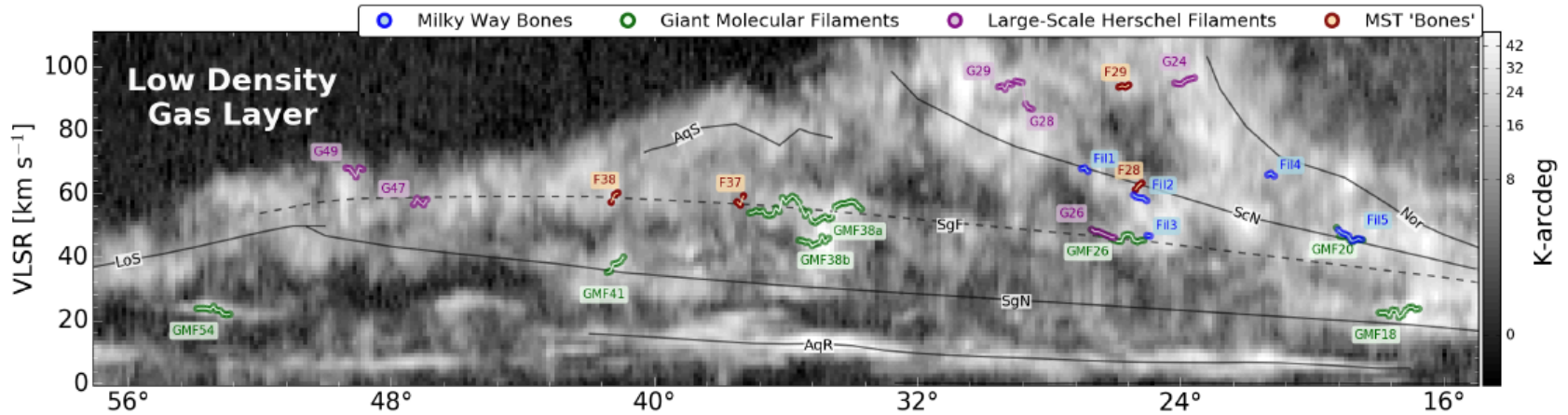
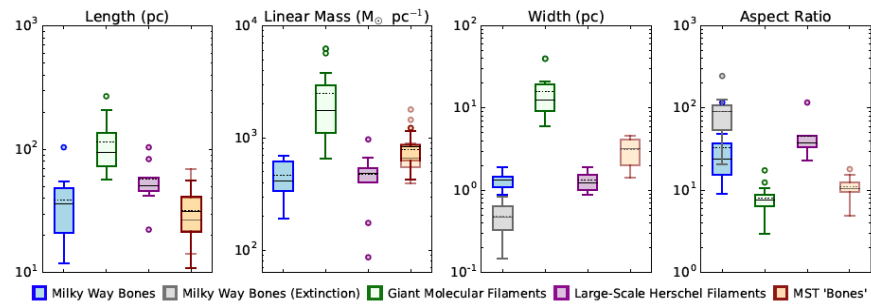

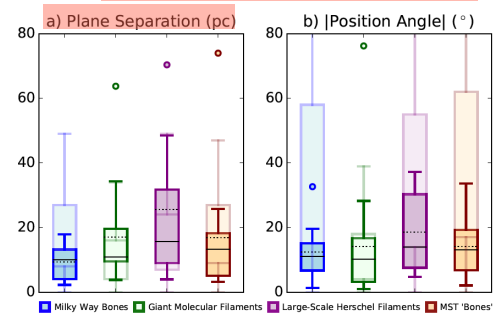
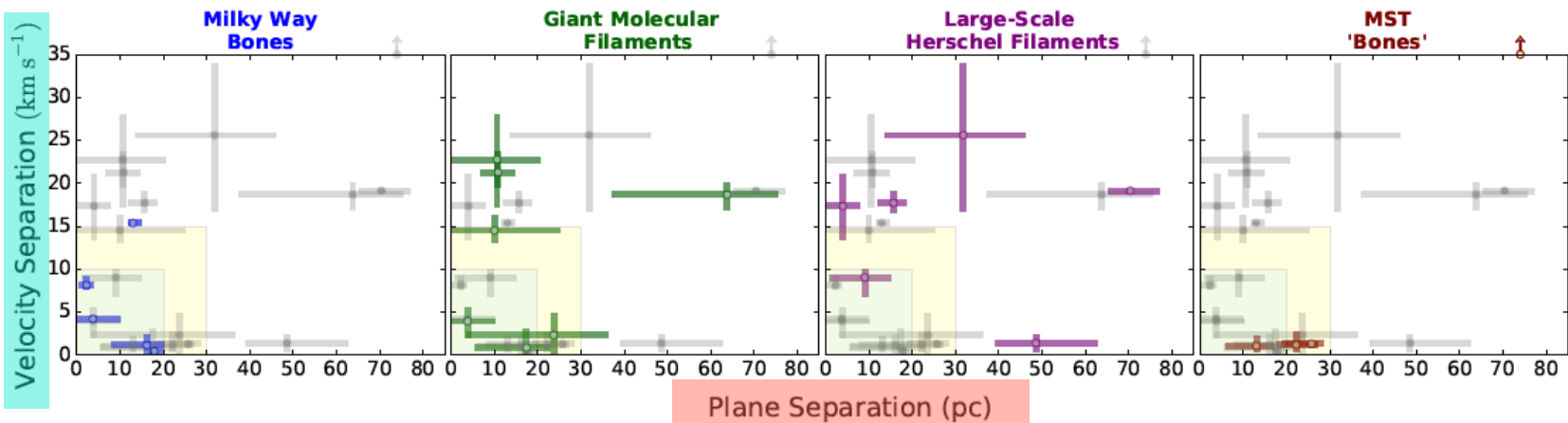
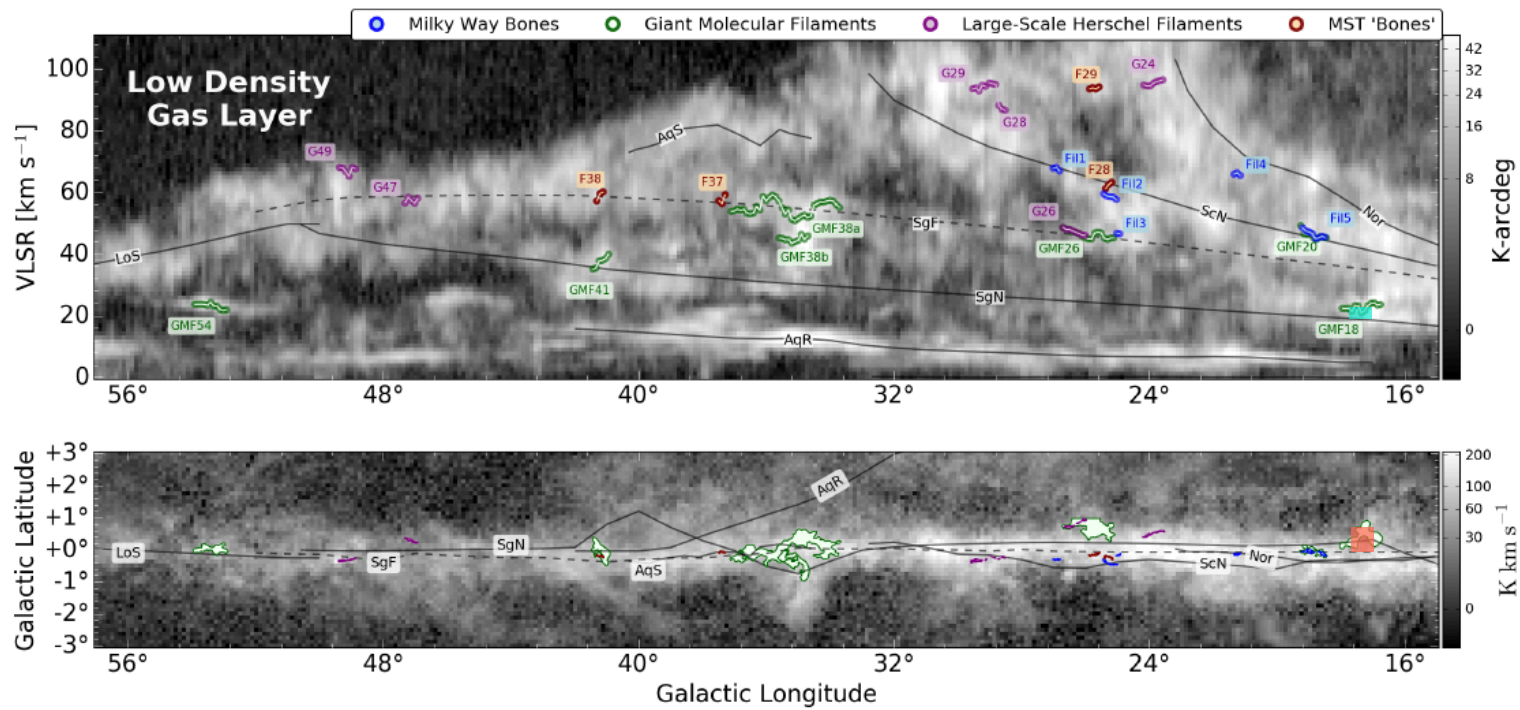

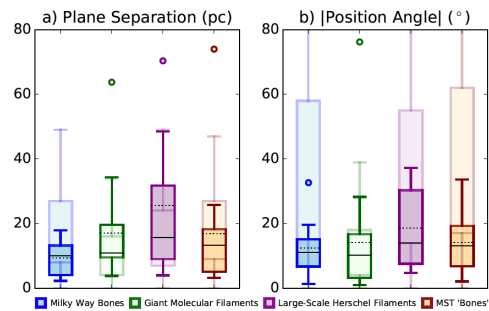
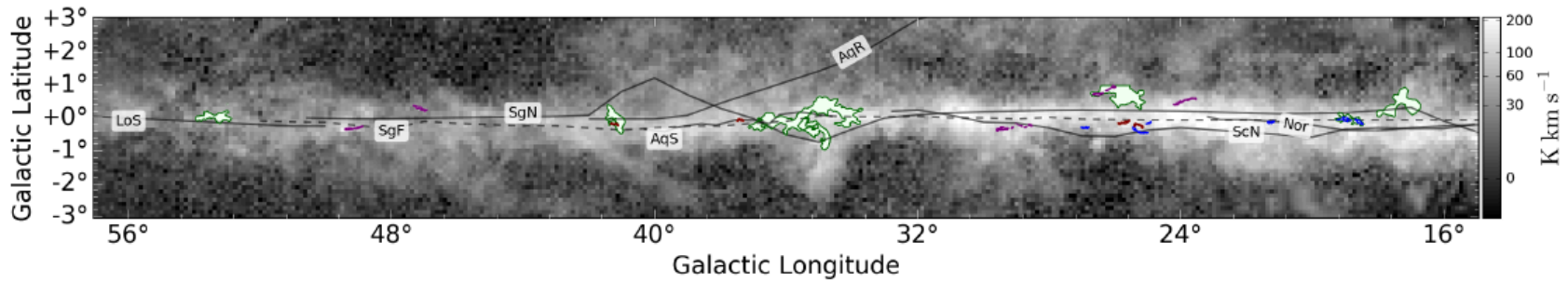
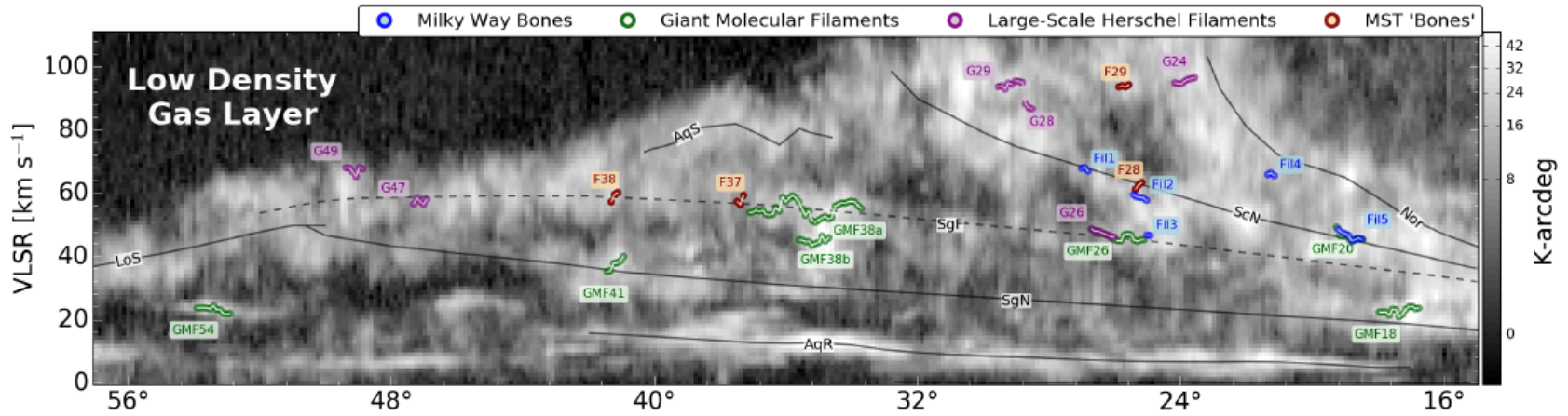
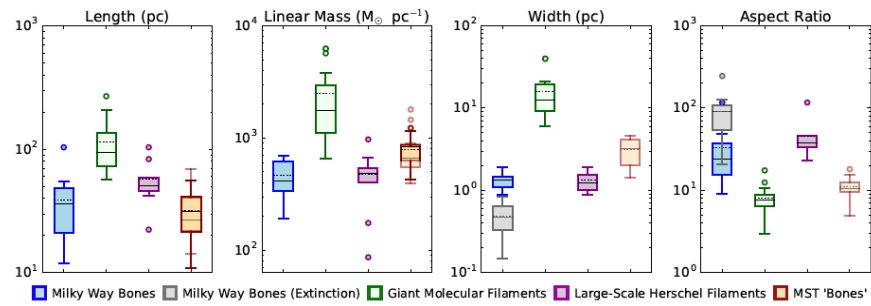

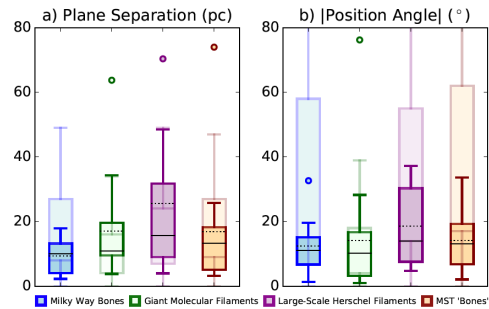
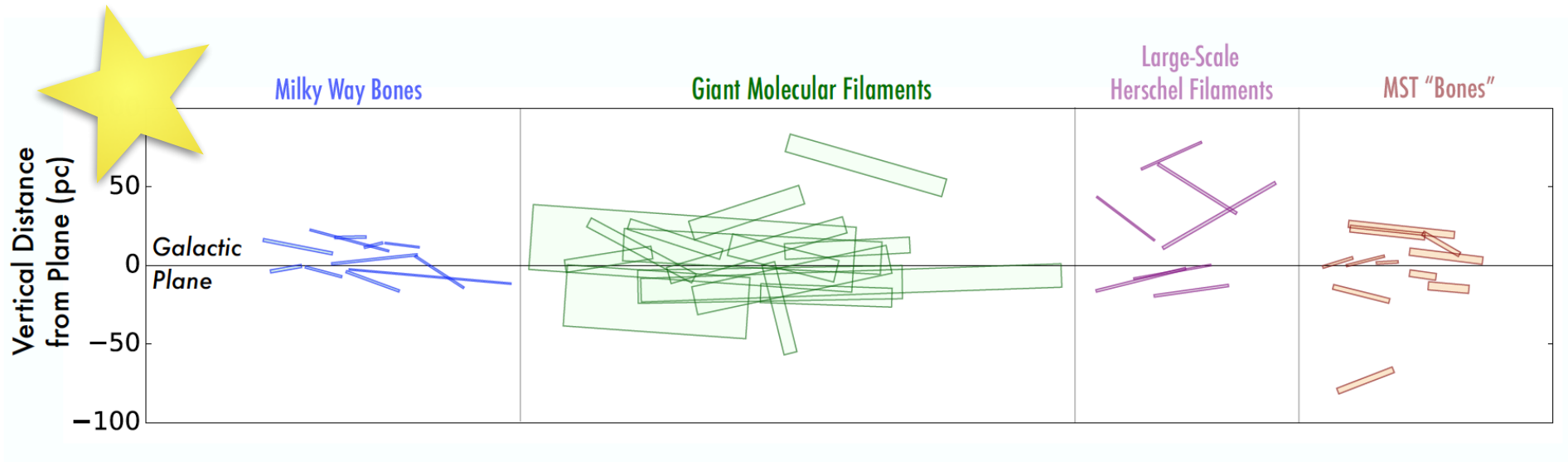
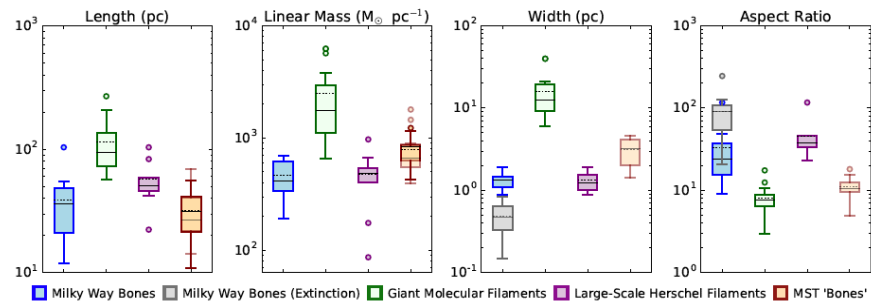

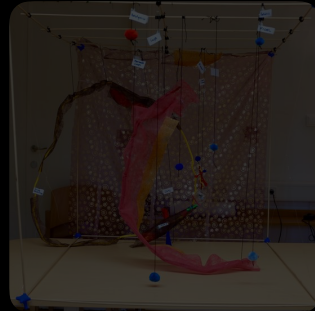
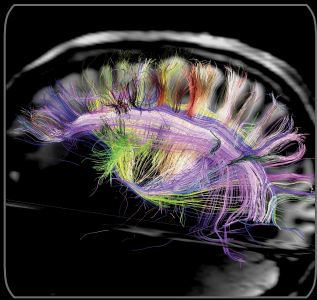
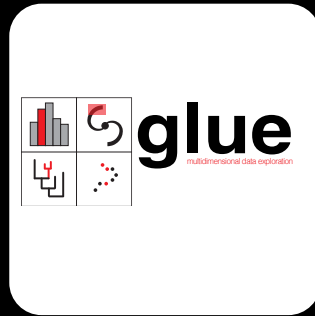
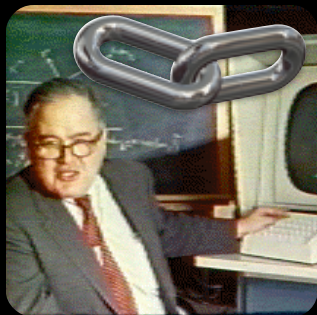
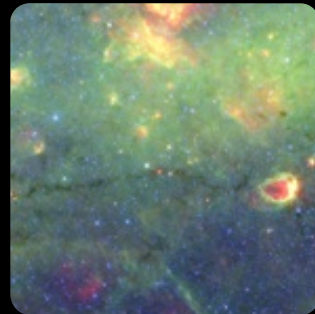
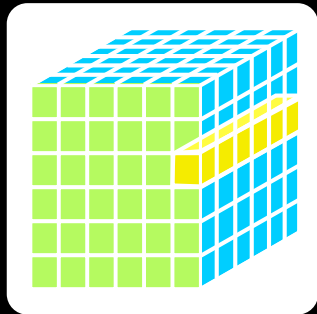
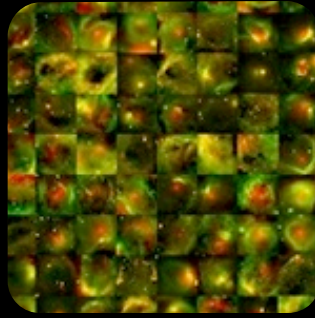

The challenge of 3D Selection

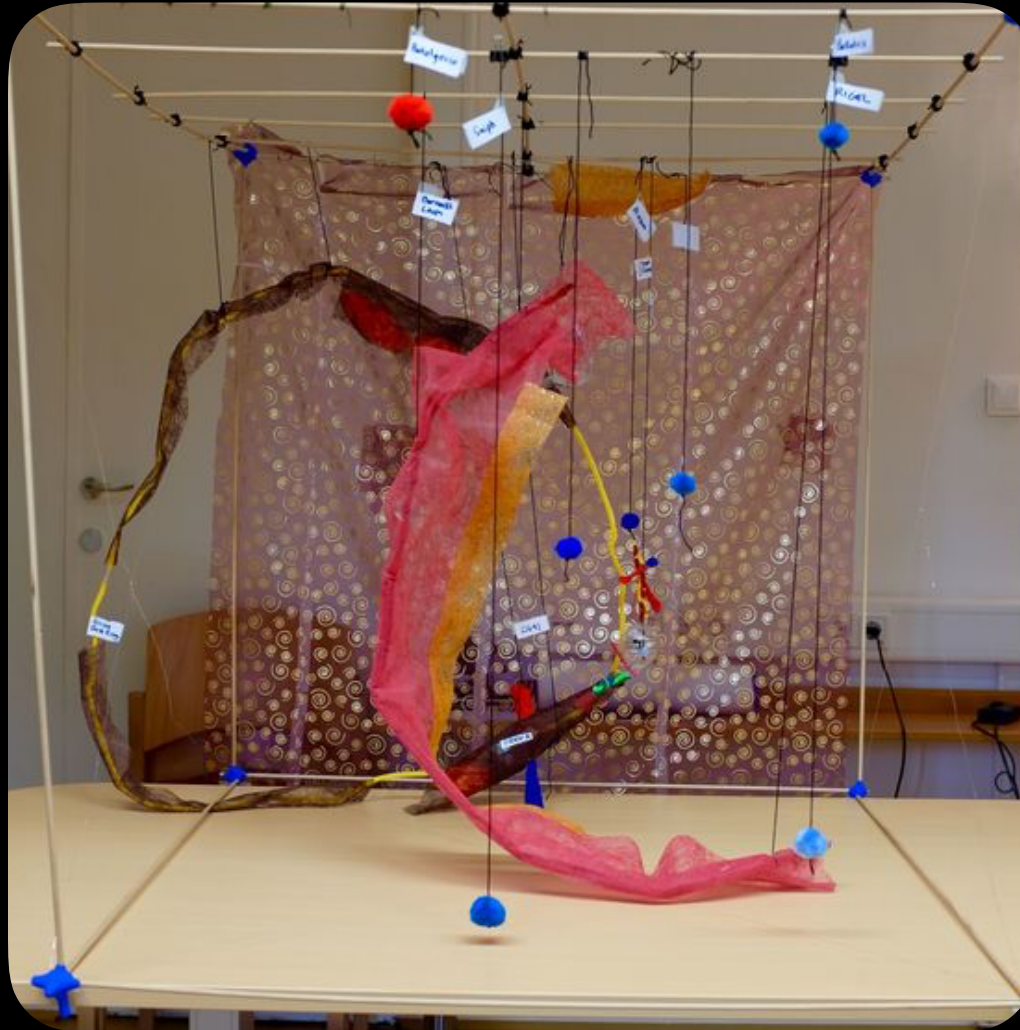

*A state-of-the-art 3D model of the stars & gas near the Orion nebula, created at Orion (un)plugged, Vienna, 2015.
Expert builders (~20 total) include: Joao Alves, John Bally, Alyssa Goodman & Eddie Schlafly. (cf. "Image & Meaning" workshops by Felice Frankel)
[YouTube video explanation](#); [WWT Tour](#)*

The challenge of 3D Selection

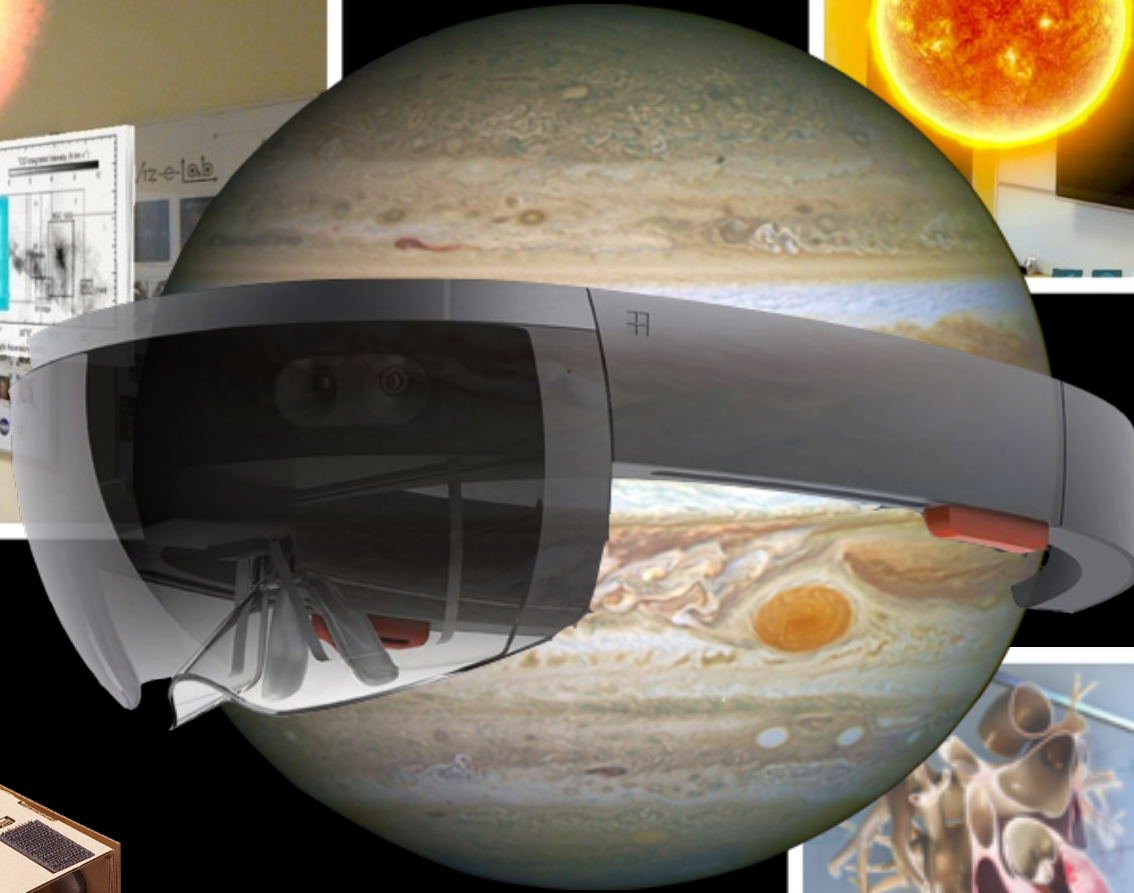
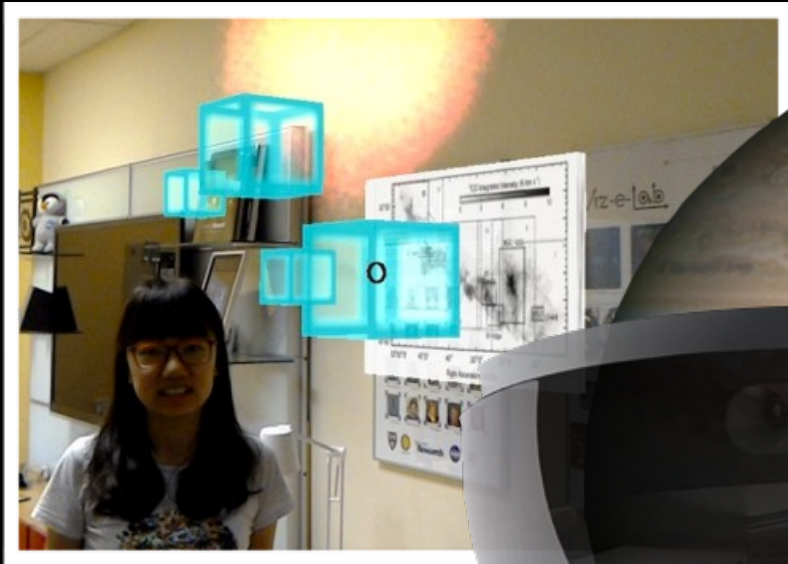

Viz-e-lab



The challenge of 3D Selection

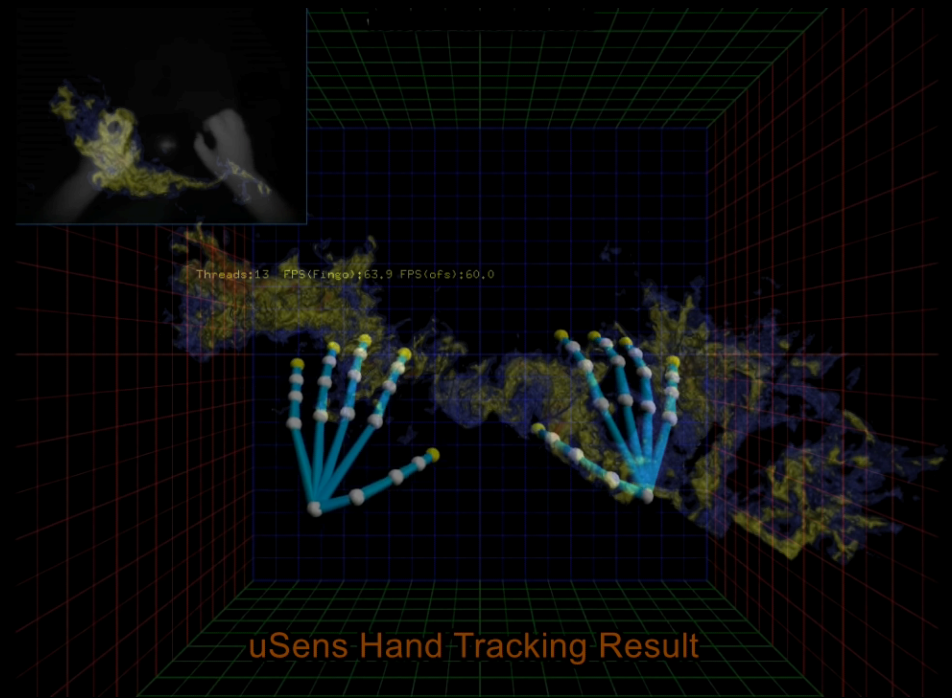



$$F = \frac{Gm_1m_2}{R^2}$$

Paper of the Future

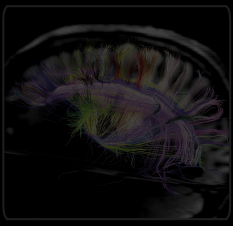
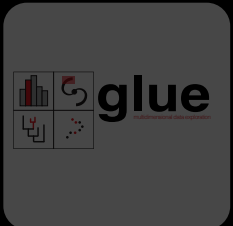
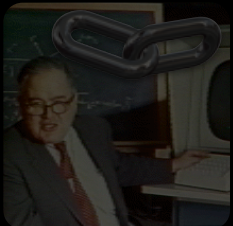
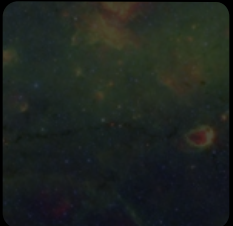
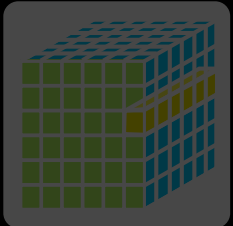
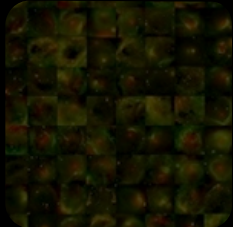
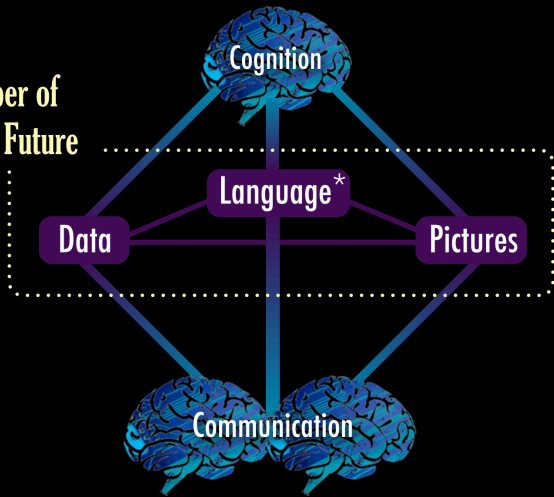

Literature as (a filter for) Data

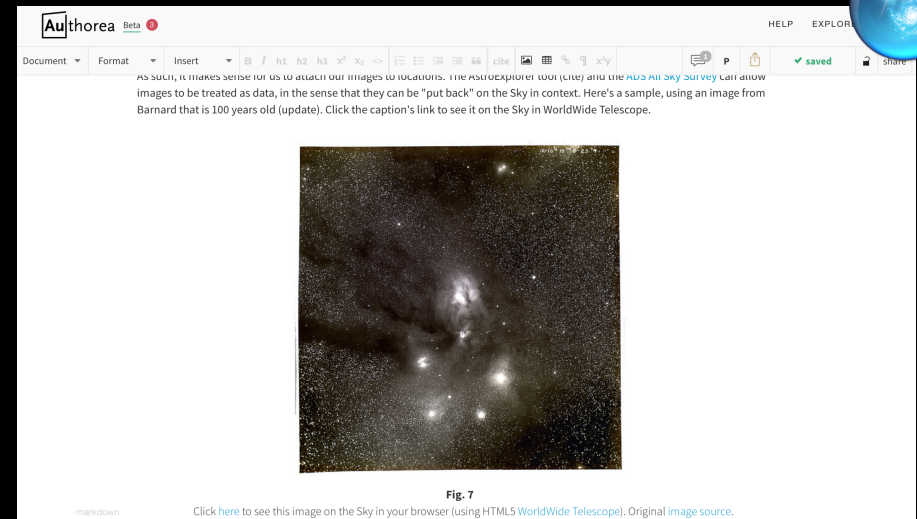
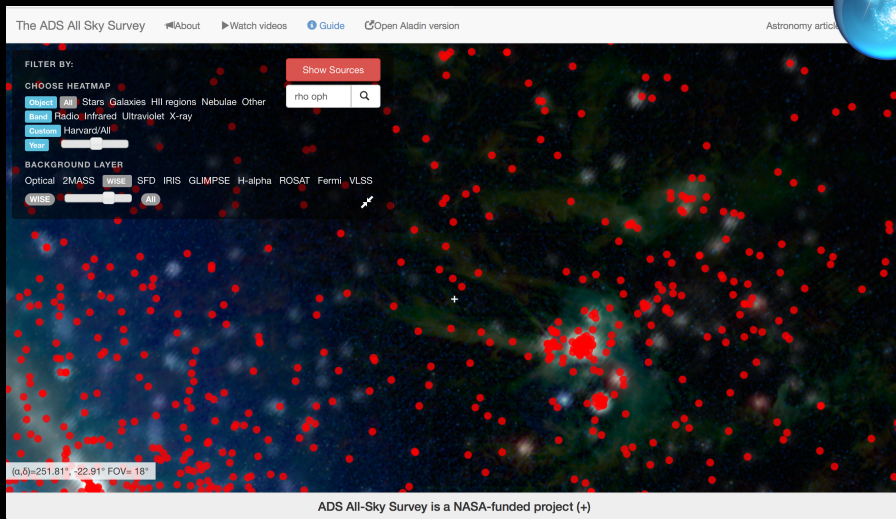
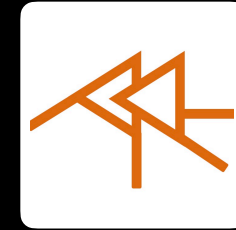

Many thanks to Alberto Pepe, August Muench, Thomas Boch, Jonathan Fay, Michael Kurtz, Alberto Accomazzi, Julie Steffen, Laura Trouille, David Hogg, Dustin Lang, Christopher Stumm, Chris Beaumont & Phil Rosenfield for making this all work!

Bringing "Dead" Data Back to Life



Document Format Insert **B** *I* h1 h2 h3 x² x₂ <> cite x²y 4 **P** saved share

markdown

5.3.3 Putting Images in Context

Most observational astronomy has the unique feature of having a specific space to which the data are attached: the celestial sphere. As such, it makes sense for us to attach our images to locations. The AstroExplorer tool ([cite](#)) and the [ADS All Sky Survey](#) can allow images to be treated as data, in the sense that they can be "put back" on the Sky in context. Here's a sample, using an image from Barnard that is 100 years old (update). Click the caption's link to see it on the Sky in WorldWide Telescope.



Fig. 7

Click [here](#) to see this image on the Sky in your browser (using HTML5 [WorldWide Telescope](#)). Original [image source](#).



ADS All-Sky Survey & Astronomy Rewind

"putting articles and images (back) on the Sky"

1. Images Extracted from Journal Articles

ON A GREAT NEBULOUS REGION AND ON THE QUESTION OF ABSORBING MATTER IN SPACE AND THE TRANSPARENCY OF THE NEBULAE
By E. E. BARNARD

While photographing the region of the great nebula of ρ Ophiuchi (which I had found with the Willard lens) at the Lick Observatory in 1893, the plates with the small lantern lens (4 inches diameter, also attached to the Willard mounting) showed a remarkable nebula involving the 4.5 magnitude star ρ Scorpii (Plate I). It had not been noticed on the Willard lens photographs, where it was very faint and near the edge of the plate. The discovery of this object therefore is due to the small lantern lens.

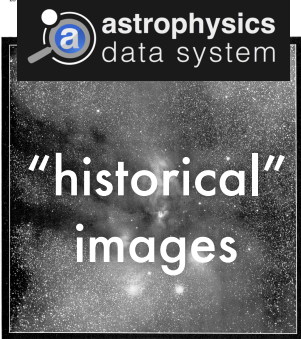

THE COMPLETE SURVEY OF STAR-FORMING REGIONS: PHASE I DATA
Nuno A. Alves,¹ Javier D. Fernández,² Hugo Kim,³ Di Li,⁴ Andre A. Gouveia,⁵ João F. Alves,⁶ Bruno G. Amorim,⁷ Mariana A. Bragança,⁸ Paula Coelho,⁹ Jonathan B. Forten,¹⁰ Maria R. Hens,¹¹ David Johnston,¹² David A. Koenig,¹³ Marco Lovagano,¹⁴ James E. Priddy,¹⁵ Scott J. Shuter,¹⁶ and Marco Trilling,¹⁷

Received 2017 December 8; accepted 2018 February 22

ABSTRACT
We present an overview of data available for the Ophiuchus and Perseus molecular clouds from Phase I of the COMPLETE Survey of Star-forming Regions. This survey provides a range of data complementary to the Spitzer

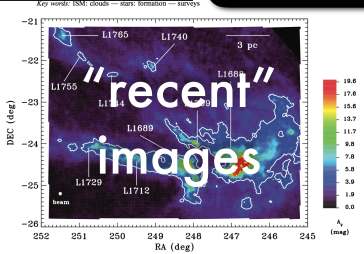

Fig. 3.—Map of structures in Ophiuchus derived using SMASS SURFER. The central position is at $\alpha = 17$ mag and is repeated in subsequent figures for orientation. Note that the small "hole" at the center of the L1688 cluster is an artifact due to the high extinction at that position.

2. Missing coordinate metadata added back to images, either...

...automatically, applying astronomy.net to wide-field optical images, or



via "Astronomy Rewind" Zooniverse Citizen Science Project



3. "Solved" images returned to ADS & Astronomy Image Explorer

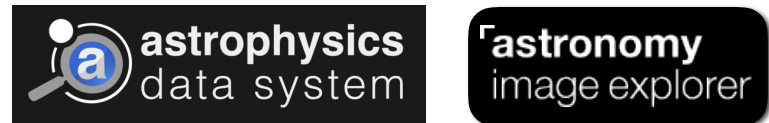

4. New button in Astronomy Image Explorer offers image-in-context, using AAS' WorldWide Telescope in the browser

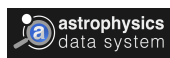
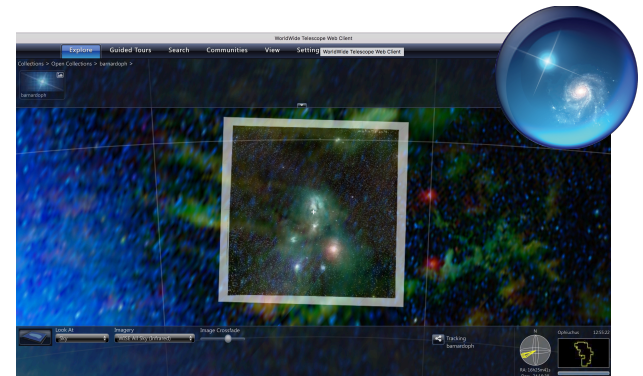

click entries on the timeline to try out services



WorldWide Telescope
2008



Zooniverse
2009



Astrometry.net
2011



ADS All Sky Survey
2014



Astronomy Image Explorer
2014



Astronomy Rewind
2017

THE COMPLETE SURVEY OF STAR-FORMING REGIONS: PHASE I DATA

NAOMI A. RIDGE,¹ JAMES DI FRANCESCO,² HELEN KIRK,^{2,3} DI LI,^{1,4} ALYSSA A. GOODMAN,¹ JOÃO F. ALVES,⁵
 HÉCTOR G. ARCE,⁶ MICHÉLLE A. BORKIN,⁷ PAOLA CASELLI,⁸ JONATHAN B. FOSTER,¹ MARK H. HEYER,⁹
 DOUG JOHNSTONE,^{2,3} DAVID A. KOSSLYN,¹ MARCO LOMBARDI,⁴ JAIME E. PINEDA,¹
 SCOTT L. SCHNEE,¹ AND MARIO TAFALLA^{1,0}

Received 2005 November 8; accepted 2006 February 22

ABSTRACT

We present an overview of data available for the Ophiuchus and Perseus molecular clouds from Phase I of the COMPLETE Survey of Star-Forming Regions. This survey provides a range of data complementary to the *Spitzer* Legacy Program “From Molecular Cores to Planet Forming Disks.” Phase I includes the following: extinction maps derived from the Two Micron All Sky Survey (2MASS) near-infrared data using the NICER algorithm; extinction and temperature maps derived from *IRAS* 60 and 100 μm emission; H I maps of atomic gas; ^{12}CO and ^{13}CO maps of molecular gas; and submillimeter continuum images of emission from dust in dense cores. Not unexpectedly, the morphology of the regions appears quite different depending on the column density tracer that is used, with *IRAS* tracing mainly warmer dust and CO being biased by chemical, excitation, and optical depth effects. Histograms of column density distribution are presented, showing that extinction as derived from 2MASS NICER gives the closest match to a lognormal distribution, as is predicted by numerical simulations. All the data presented in this paper, and links to more detailed publications on their implications, are publicly available at the COMPLETE Web site.

Key words: ISM: clouds — stars: formation — surveys

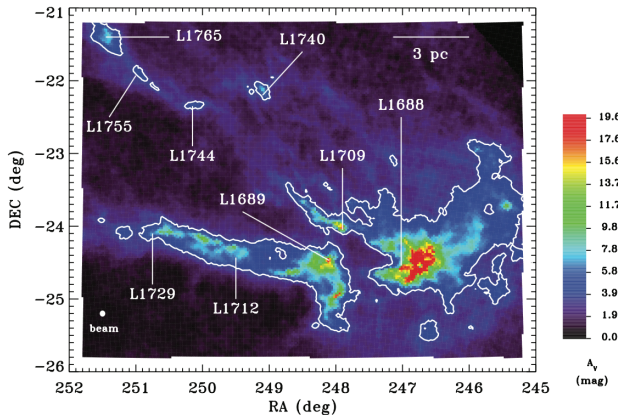

FIG. 3.—Map of extinction in Ophiuchus derived using 2MASS NICER. The contour indicates an A_V of 3 mag and is repeated in subsequent figures for orientation. Note that the small “hole” at the center of the L1688 cluster is an artifact due to the high extinction at that position.

astronomy
image explorer

Who, How, and Who's Paying?

The **ADS All Sky Survey** was first funded via a 2012 grant from the **NASA ADAP** program to Seamless Astronomy, in collaboration with CDS, Astrometry.net and Microsoft Research.

Articles-on-the-Sky

was first deployed in 2014, using APIs from WWT (Microsoft Research, now AAS) and CDS (Aladin)

Images-on-the-Sky

relies on the astrometry.net, Zooniverse, IOP/AAS Astronomy Image Explorer and WorldWide Telescope platforms, and it is funded by the **American Astronomical Society**, in addition to the NASA ADAP grant.

These projects rely on open source software, primarily hosted on **GitHub**.

PI to contact for more information
 Alyssa Goodman, Harvard
 agoodman@cfa.harvard.edu



your handout

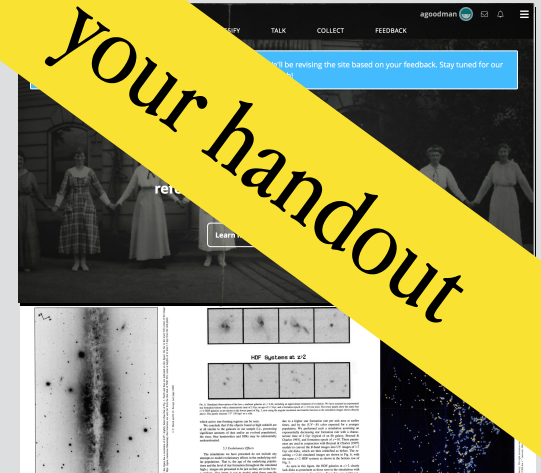

1 person is talking about Astronomy Rewind right now.

Join in

ASTRONOMY REWIND STATISTICS

100% Complete

201

Volunteers

1,987

Classifications

360

Subjects

360

Completed Subjects

WORDS FROM THE RESEARCHER



"Your contributions unlock the information from old astronomy journals. Thank you and enjoy the images!"

ABOUT ASTRONOMY REWIND

This project is part of an ongoing NASA-funded effort aimed at turning the SAO/NASA Astrophysics Data System (ADS) into a data resource. The result will be a database of astro-referenced images, i.e., images of the sky for which coordinates, orientation, and pixel scale will be publicly available through NASA data archives, the Astronomy Image Explorer, and WorldWide Telescope, thanks to your help!



ZOONIVERSE





Seeing the Sky

Visualization & Astronomers

Alyssa A. Goodman

Harvard Smithsonian Center for Astrophysics & Radcliffe Institute for Advanced Study

@aagie



HARVARD
UNIVERSITY

Microsoft
Research



SEAMLESS
ASTRONOMY
Linking scientific data, publications, and communities



Authorea

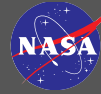

AMERICAN ASTRONOMICAL SOCIETY
Enhancing and sharing humanity's scientific understanding of the universe since 1899.

To continue the conversation...

≡ MENU



TEN QUESTIONS TO ASK WHEN CREATING A VISUALIZATION

The 10 Questions

1. **Who** | *Who is your audience? How expert will they be about the subject and/or display conventions?*
2. **Explore-Explain** | *Is your goal to explore, document, or explain your data or ideas, or a combination of these?*
3. **Feature & Pattern Recognition** | *Is feature and/or pattern recognition, a goal?*
4. **Predictions & Uncertainty** | *Are you making a comparison between data and/or predictions? Is representing uncertainty a concern?*
5. **Dimensions** | *What is the intrinsic number of dimensions (not necessarily spatial) in your data, and how many do you want to show at once?*
6. **Categories & Clustering** | *Are there natural, or imposed, categories within the data? Are you interested in clustering?*
7. **Abstraction & Accuracy** | *Do you need to show all the data, or is summary or abstraction OK?*
8. **Context & Scale** | *Can you, and do you want to, put the data into a standard frame of reference, coordinate system, or show scale(s)?*
9. **Metadata** | *Do you need to display or link to non-quantitative metadata? (including captions, labels, etc.)*
10. **Display Modes** | *What display modes might be used in experiencing your display?*

 [Join the 10Qviz Conversation!](#) 



10qviz.org with Arzu Çöltekin (beta 2017, release 2018)

A poster for the 'Creativity & Collaboration' colloquium. The top half features a colorful, abstract background with a grid of orange and red squares. Below this is a central illustration of several birds perched on a branch, with a cluster of blue and cyan bubbles or data points below them. The bottom half of the poster has a dark background with a repeating pattern of white bird silhouettes. Text on the poster includes the title 'Creativity & Collaboration: Revisiting Cybernetic Serendipity', the event details 'National Academy of Sciences Sackler Colloquium, March 13-14, 2018, Washington, DC', and the role 'Role/Play: Collaborative Creativity and Creative Collaborations' from the 'National Academy of Sciences Sackler Student Fellows Symposium, March 12, 2018, Washington DC'. At the bottom, there is a website URL 'www.nasonline.org/Sackler-Creativity-Collaboration' and logos for the Sackler Colloquium and Google.

*Creativity & Collaboration
at NAS March 2018*

*with Ben Shneiderman,
Maneesh Agrawala, Roger Malina,
Youngmoo Kim & Donna Cox*